

F01 锁具 LOCK KIT

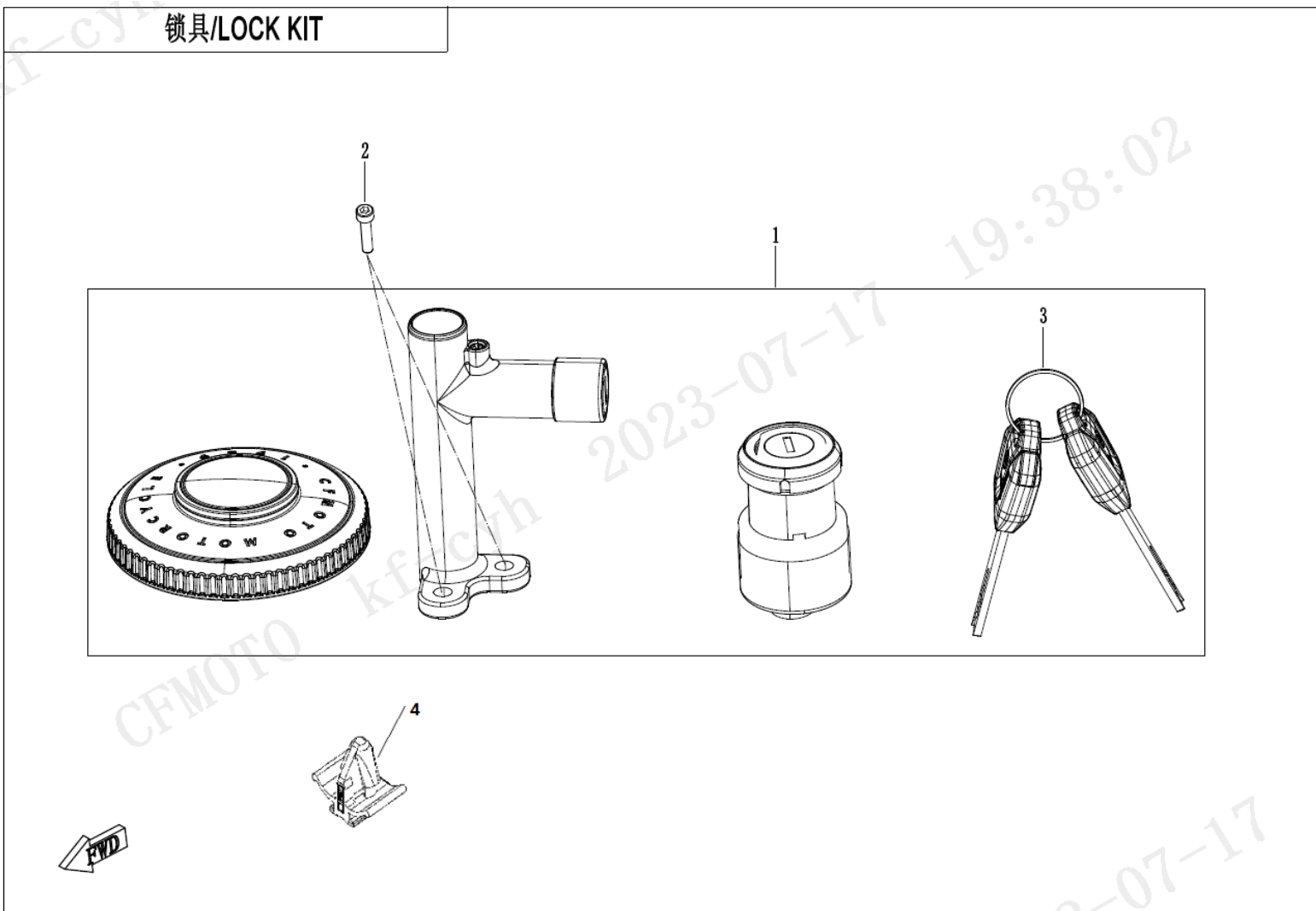

NO.	CODE	EN DESCRIPTION	QTY	REMARKS
F01-01	6AQV-011000-7101	LOCK KIT	1	
F01-02	30102-060016870	SCREW M6x16	2	
F01-03	6AQV-011020-7100	KEY	2	
F01-04	CFCV-CAC002-2000-M1	CLIP	1	

消声器/MUFFLER

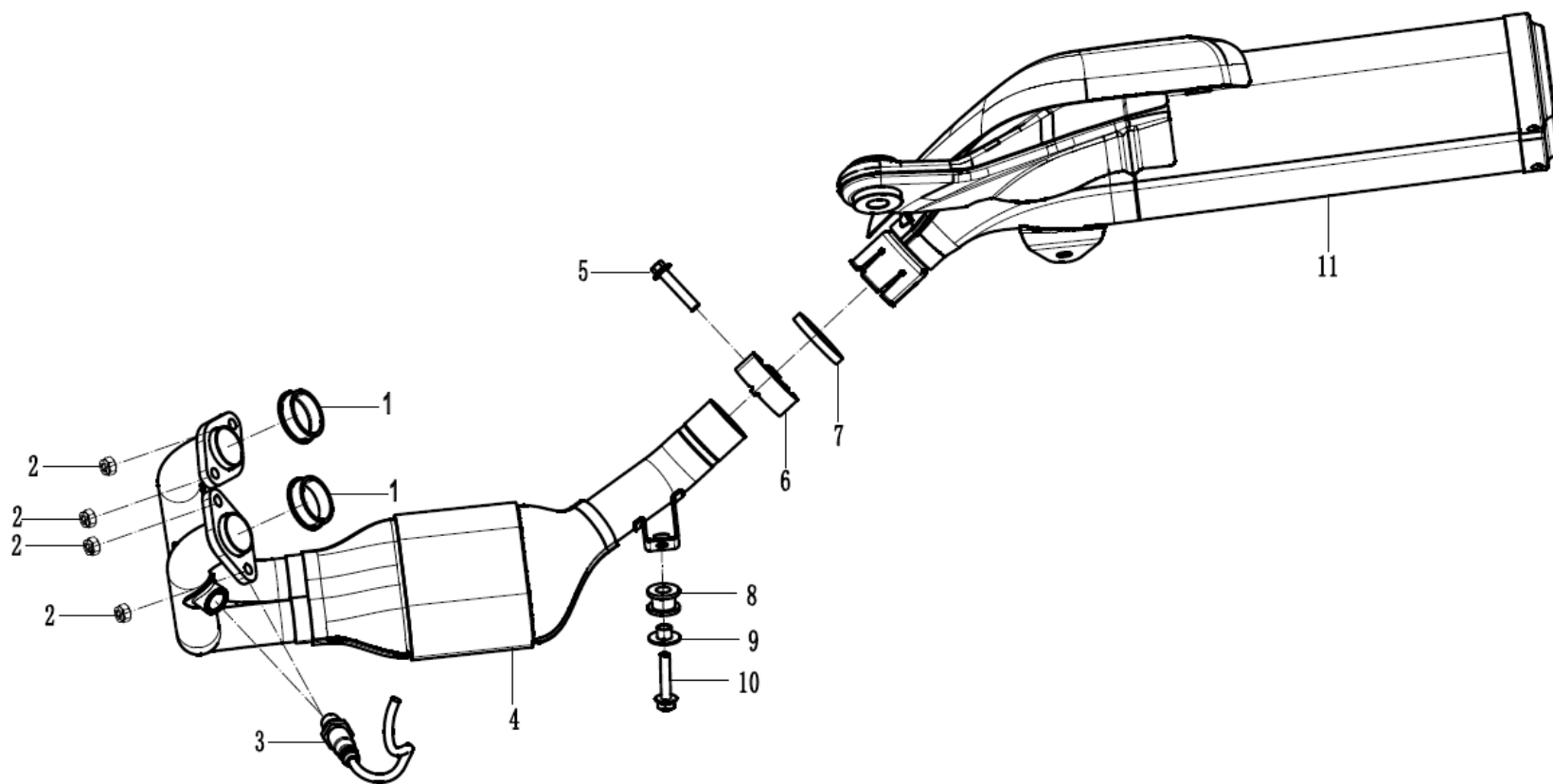

NO.	CODE	EN DESCRIPTION	QTY	REMARKS
F02-01	6090-020010	GASKET, EXHAUST PORT	2	
F02-02	6L30-020005	LOCK NUT	4	
F02-03	0HU0-176000	OXYGEN SENSOR	2	
F02-04	6AQV-021100-7100-0D700	EXHAUST PIPE ASSY (MATTE BLACK)	1	
F02-05	30006-080035810	BOLT M8X35	1	
F02-06	6AQV-021500-1000	CLAMP KIT	1	
F02-07	6AQV-021400-1000	SEAL SLEEVE, GRAPHITE	1	
F02-08	6KJ0-020003	BUSHING, MUFFLER	1	
F02-09	6KJ0-020004	BUSHING, MUFFLER	1	
F02-10	30006-080040810	BOLT M8X40	1	
F02-11	6AQV-021300-7100-0DN00	MUFFLER ASSY (CERAMIC BLACK)	1	

车架总成/FAME ASSY

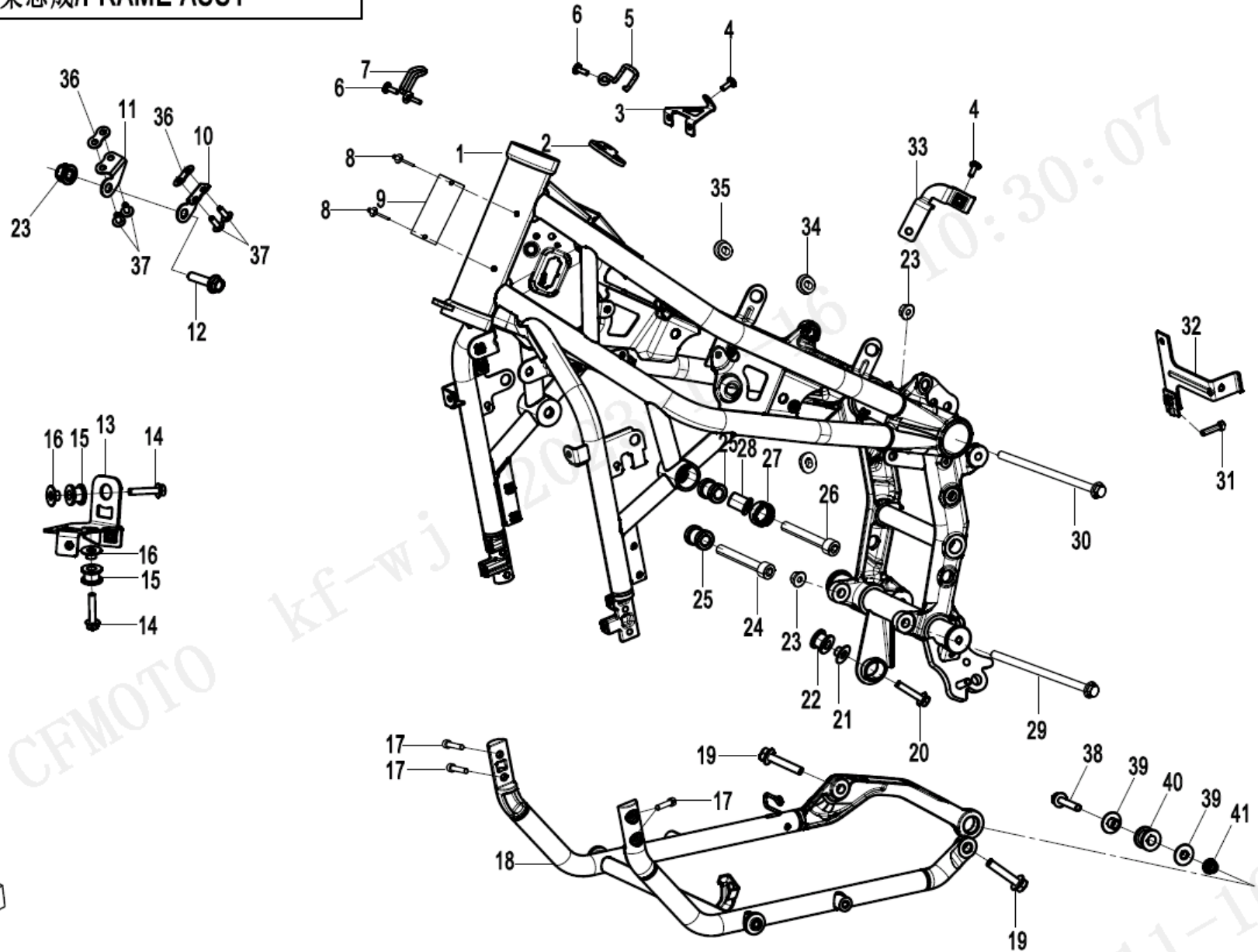

NO.	CODE	EN DESCRIPTION	QTY	REMARKS
F03-1-01	6AQV-033000-7101-0BP00	FRONT FRAME ASSY (MAUD SPIRIT BLACK)	1	
F03-1-02	6AQV-033098-7100	DEAD BOLT PLATE	1	
F03-1-03	6AQV-030290-7100	BRACKET, ROLL-OVER SENSOR	1	
F03-1-04	30006-060012870	BOLT M6X12	2	ALT:- 30006-060012810
F03-1-05	6AQV-030480-7100	THROTTLE CABLE CLIP	1	
F03-1-06	6WWV-047102-5000	INNER HEX SCREW M5x14	2	
F03-1-07	6AQV-030470-7100	CABLE CLIP	1	
F03-1-08	30902-0401320	RIVET GB/T12618_4.2X8	2	
F03-1-09	6FIA-190012	VIN PLATE	1	
F03-1-10	6AQV-030410-7100-0BP00	HEADLIGHT LH BRACKET (MAUD SPIRIT BLACK)	1	
F03-1-11	6AQV-030420-7100-0BP00	HEADLIGHT RH BRACKET (MAUD SPIRIT BLACK)	1	
F03-1-12	30006-102040810	BOLT M10X1.25X40	1	
F03-1-13	6AQV-030250-7100	ABS BRACKET	1	
F03-1-14	30006-060016870	BOLT M6X16	2	ALT:- 30006-060016810
F03-1-15	6WWV-030019-5000	CUSHION SLEEVE	2	
F03-1-16	9060-180029	RADIATOR SLEEVE TUBE	2	
F03-1-17	30102-080020870	SCREW M8X20	4	
F03-1-18	6AQV-030700-7100-0BP00	BOTTOM BRACKET (MAUD SPIRIT BLACK)	1	
F03-1-19	30006-080030870	BOLT M8X30	2	
F03-1-20	30006-080045810	BOLT M8X45	1	
F03-1-21	6KJ0-020004	BUSHING, MUFFLER	1	
F03-1-22	6KJ0-020003	BUSHING, MUFFLER	1	
F03-1-23	30204-102810	NUT M10X1.25	3	
F03-1-24	6WWV-030011-5000	INNER HEX SCREW M10x45	1	
F03-1-25	6AQV-030004-1000	BUSHING, ENGINE	2	
F03-1-26	6AQV-030093-1000	INNER HEX SCREW	1	
F03-1-27	6NT1-000292	NUT M18	1	
F03-1-28	6AQV-030092-1000	ADJUSTING SCREW, ENGINE	1	
F03-1-29	30001-102170110	BOLT M10X1.25X170	1	
F03-1-30	30001-102150110	BOLT M10x1.25x150	1	
F03-1-31	30102-060020870	INNER HEX SCREW M6x20	1	
F03-1-32	6AQV-030350-7100	REGULATOR BRACKET	1	

NO.	CODE	EN DESCRIPTION	QTY	REMARKS
F03-1-33	6AQV-030003-4000	FLUID RESERVOIR BRACKET	1	
F03-1-34	6KWV-041114-1000	RUBBER HEAD	4	
F03-1-35	6KMV-041112-3000	M6 RUBBER SLEEVE	2	
F03-1-36	6AQV-030460-7100	HEADLIGHT RUBBER	2	
F03-1-37	6WWV-046802-5000	INNER HEX SCREW M6×16	4	
F03-1-38	30006-080040810	BOLT M8X40	1	
F03-1-39	6GU#-020002-6001	BUSHING	2	
F03-1-40	A000-020004	DAMPER, MUFFLER	1	
F03-1-41	30204-080810	LOCK NUT M8	1	

车架总成/FRAME ASSY

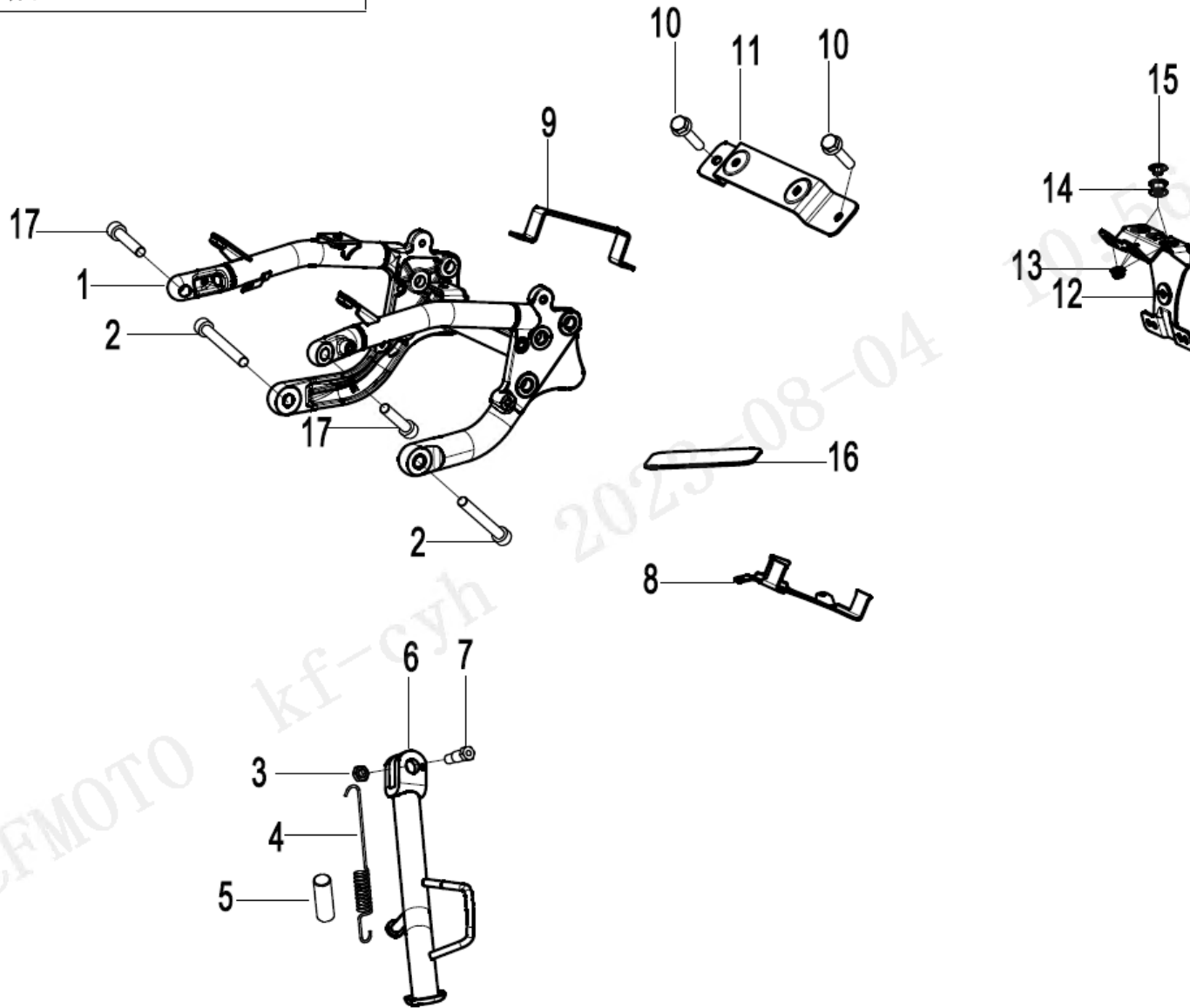

NO.	CODE	EN DESCRIPTION	QTY	REMARKS
F03-2-01	6AQV-032000-7100-0BP00	REAR FRAME ASSY (MAUD SPIRIT BLACK)	1	
F03-2-02	6WWV-030017-5000	INNER HEX SCREW M10x30	2	
F03-2-03	30208-102010	NUT M10X1.25	1	
F03-2-04	A000-030210	SIDE STAND SPRING ASSY	1	
F03-2-05	A000-030004	SIDE STAND SPRING SLEEVE	1	
F03-2-06	6AQV-030600-7100-0BP00	SIDE STAND ASSY (MAUD SPIRIT BLACK)	1	
F03-2-07	6080-030004	SIDE STAND BOLT	1	
F03-2-08	6AQV-030260-7100	ECU BRACKET	1	
F03-2-09	6AQV-030360-7100	BATTERY PLATE	1	
F03-2-10	30006-060016810	BOLT M6X16	2	ALT:- 30006-060016870
F03-2-11	6AQV-030120-7100	SEAT SUPPORT	1	
F03-2-12	6AQV-030370-7100	TAIL LIGHT BRACKET	1	
F03-2-13	30204-060810	NUT M6	4	ALT:- 30202-060110
F03-2-14	6WWV-030019-5000	CUSHION SLEEVE	2	
F03-2-15	9060-180029	RADIATOR SLEEVE TUBE	2	
F03-2-16	6AQV-041116-1000	FRAME STICKER	1	
F03-2-17	6L30-030092	BOLT M10x22	2	

塑料件 I / PLASTICS I

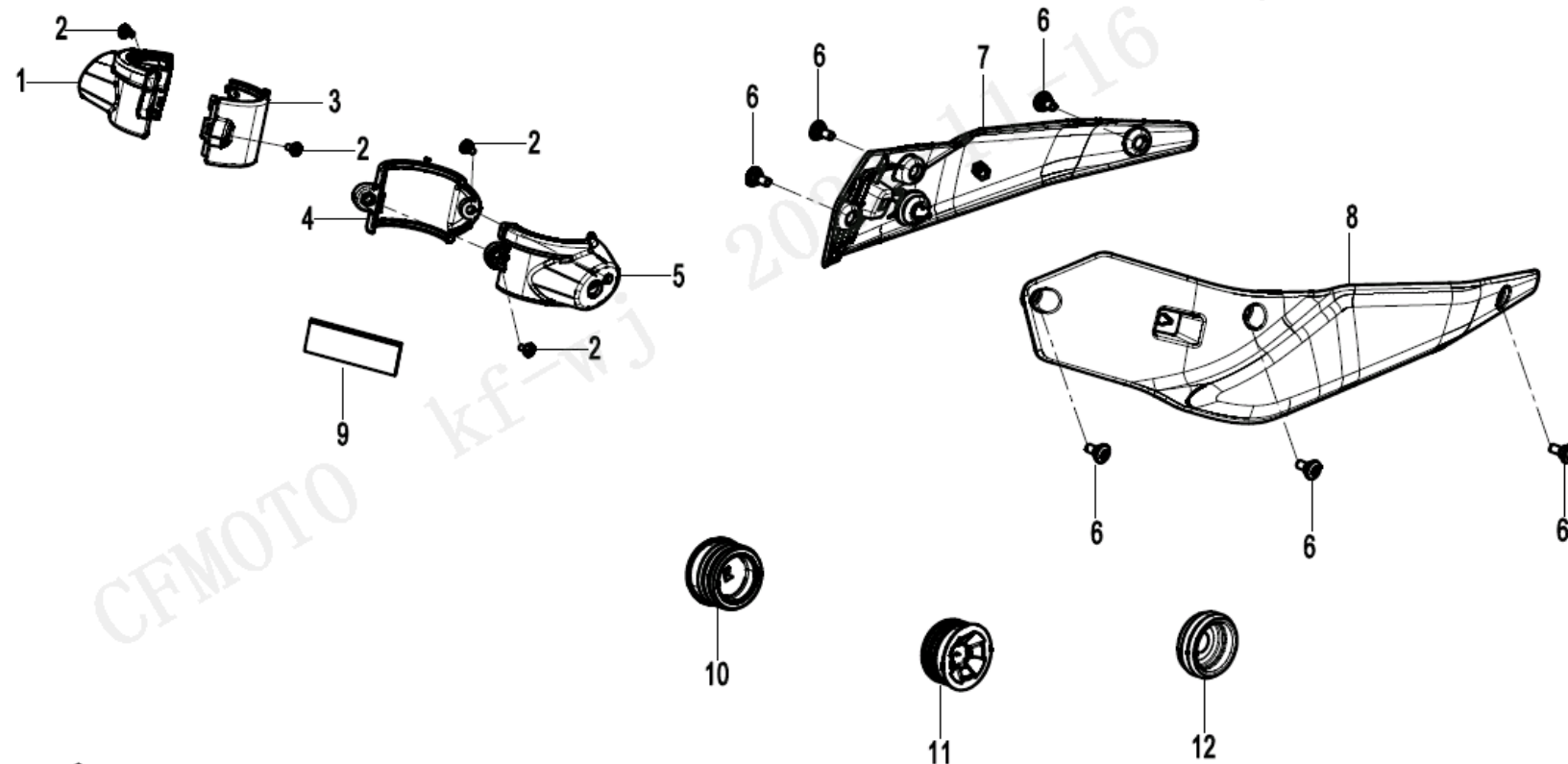

11-16

NO.	CODE	EN DESCRIPTION	QTY	REMARKS
F04-1-01	6AQV-040102-7100	FRONT RH TURN LIGHT BRACKET	1	
F04-1-02	30102-050012870	SCREW M5X12	4	
F04-1-03	6AQV-040104-7100	FRONT RH TURN LIGHT COVER	1	
F04-1-04	6AQV-040103-7100	FRONT LH TURN LIGHT COVER	1	
F04-1-05	6AQV-040101-7100	FRONT LH TURN LIGHT BRACKET	1	
F04-1-06	6WWV-046502-5000	STEPPED SCREW M5	6	
F04-1-07	6AQV-040402-7100	FUEL TANK RH PANEL	1	
F04-1-08	6AQV-040401-7100	FUEL TANK LH PANEL	1	
F04-1-09	6AQV-041106-7100	TURN LIGHT CAP TAPE	2	
F04-1-10	6AQV-040304-4000	FRAME RH DECO COVER	1	
F04-1-11	6AQV-040303-4000	FRAME LH DECO COVER	1	
F04-1-12	6AQV-041107-7100	MUFFLER RH PLUG	1	

塑料件 II / PLASTICS II

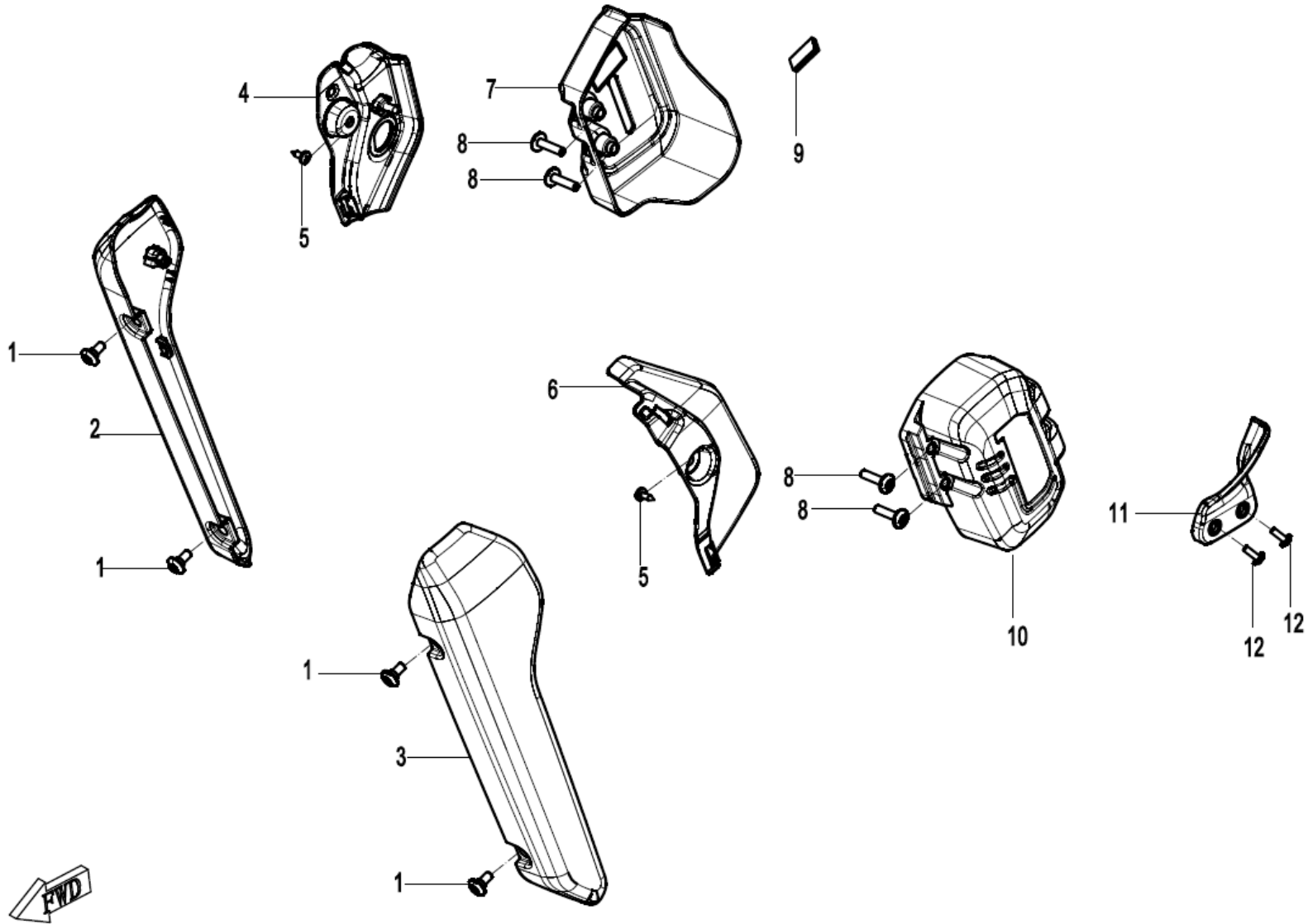

NO.	CODE	EN DESCRIPTION	QTY	REMARKS
F04-2-01	6WWV-046602-5000	INNER HEX STEPPED SCREW M6x14	4	
F04-2-02	6AQV-040502-7100-0BU00	RH PANEL,RESERVOIR (MIST SILVER BLACK)	1	
F04-2-03	6AQV-040501-7100-0BU00	LH PANEL,RESERVOIR (MIST SILVER BLACK)	1	
F04-2-04	6AQV-040514-7100	DECO PLATE, RH PANEL, RESERVOIR	1	
F04-2-05	30110-421130010	SELF-TAPPING SCREW ST4.2X13	2	
F04-2-06	6AQV-040513-7100	RESERVOIR LH PANEL DECO PLATE	2	
F04-2-07	6AQV-040509-7100	BOTTLE DECO COVER	1	
F04-2-08	6WWV-047002-5000	INNER HEX SCREW M6x25	4	
F04-2-09	9DS#-041510-6000	BUCKLE ASSY	1	
F04-2-10	6AQV-040419-7100	CANISTER COVER	1	
F04-2-11	6AQV-041401-7100	LH FOOTREST GUARD	1	
F04-2-12	6WWV-046502-5000	STEPPED SCREW M5	2	

塑料件Ⅲ/PLASTICS Ⅲ

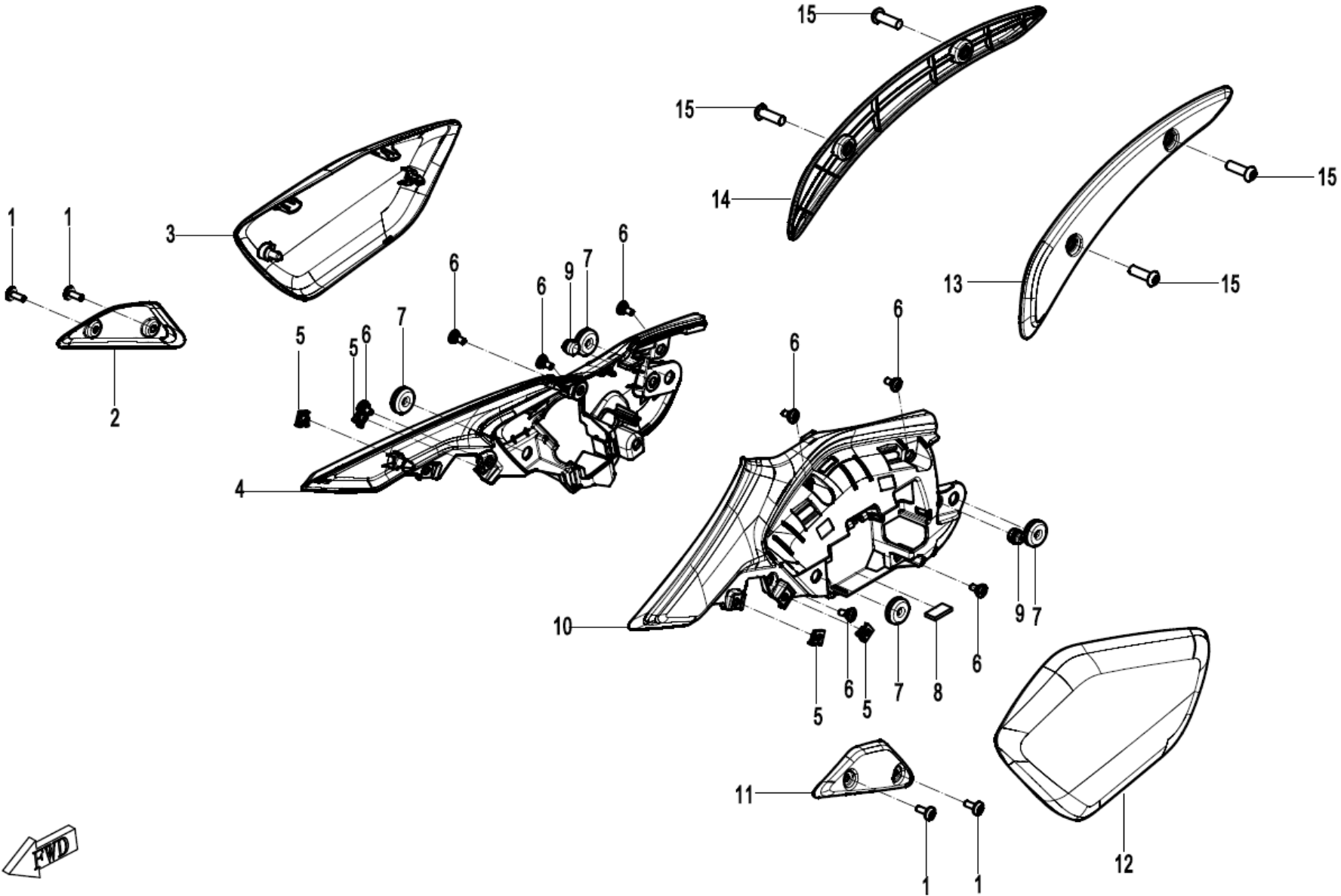

NO.	CODE	EN DESCRIPTION	QTY	REMARKS
F04-3-01	6WWV-047102-5000	INNER HEX SCREW M5x14	4	
F04-3-02	6AQV-040608-7100-OHD00	RH PANEL DECO COVER	1	
F04-3-03	6AQV-040622-7100-10-0BM00	DECAL ASSY,RH PANEL (NABULA BLACK)	1	
F04-3-04	6AQV-040604-7100	RH PANEL BASE	1	
F04-3-05	6KM#-040081-8000-M1	NUT CLIP M5	4	
F04-3-06	6WWV-046502-5000	STEPPED SCREW M5	8	
F04-3-07	6AQV-040606-7100	SIDE PANEL BUSHING	4	
F04-3-08	6KM#-160420-8001	SPONGE MAT	10	
F04-3-09	6WWV-045801-5000	RUBBER	4	
F04-3-10	6AQV-040603-7100	LH PANEL BASE	1	
F04-3-11	6AQV-040607-7100-OHD00	LH PANEL DECO COVER	1	
F04-3-12	6AQV-040621-7100-10-0BM00	DECAL ASSY,LH PANEL (NABULA BLACK)	1	
F04-3-13	6AQV-040807-7100	LH DECO COVER,REAR FENDER	1	
F04-3-14	6AQV-040808-7100	RH DECO COVER,REAR FENDER	1	
F04-3-15	30121-080020870	SCREW M8x20	4	

塑料件IV/PLASTICS IV

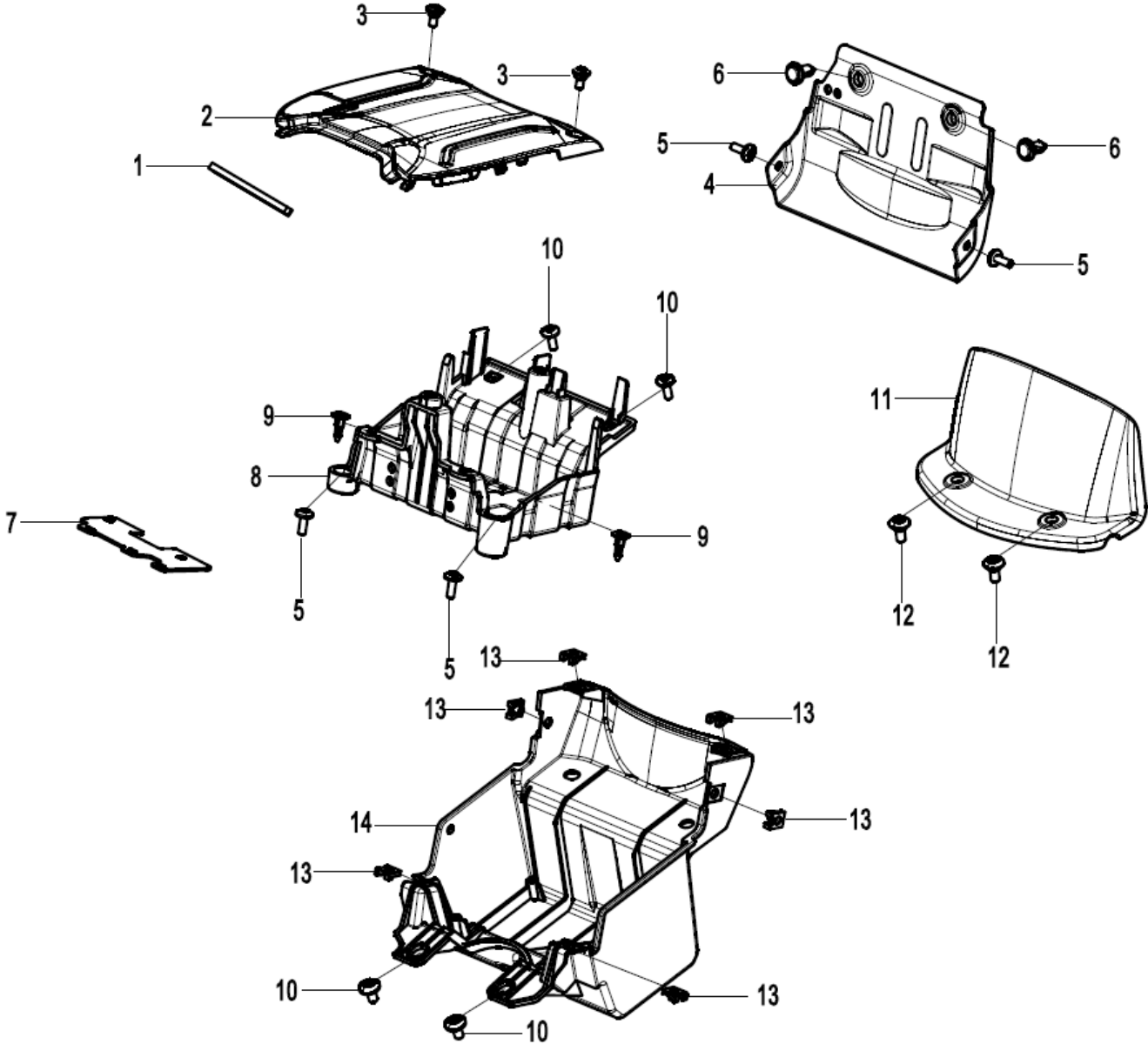

NO.	CODE	EN DESCRIPTION	QTY	REMARKS
F04-4-01	6AQV-040619-7100	SPONGE	1	
F04-4-02	6AQV-040605-7101	BATTERY BOX PRESS PLATE	1	
F04-4-03	6WWV-046502-5000	STEPPED SCREW M5	2	
F04-4-04	6AQV-041103-7100	FENDER	1	
F04-4-05	6WWV-047102-5000	INNER HEX SCREW M5x14	4	
F04-4-06	9060-040310	PLASTIC CLIPS	2	
F04-4-07	6AQV-041104-7100	HEAT INSULATOR	1	
F04-4-08	6AQV-041101-7100	BATTERY BOX	1	
F04-4-09	8080-041130	EXPANSION RIVET ASSY	2	ALT:- 8080-041131, 8080-041132
F04-4-10	6WWV-046702-5000	INNER HEX SCREW M6x12	4	
F04-4-11	6AQV-041105-7100	FENDER,REAR SHOCK ABSORBER	1	
F04-4-12	6WWV-046602-5000	INNER HEX STEPPED SCREW M6x14	2	
F04-4-13	6KM#-040081-8000-M1	NUT CLIP M5	6	
F04-4-14	6AQV-041102-7100	BATTERY BOX CARTRIDGE	1	

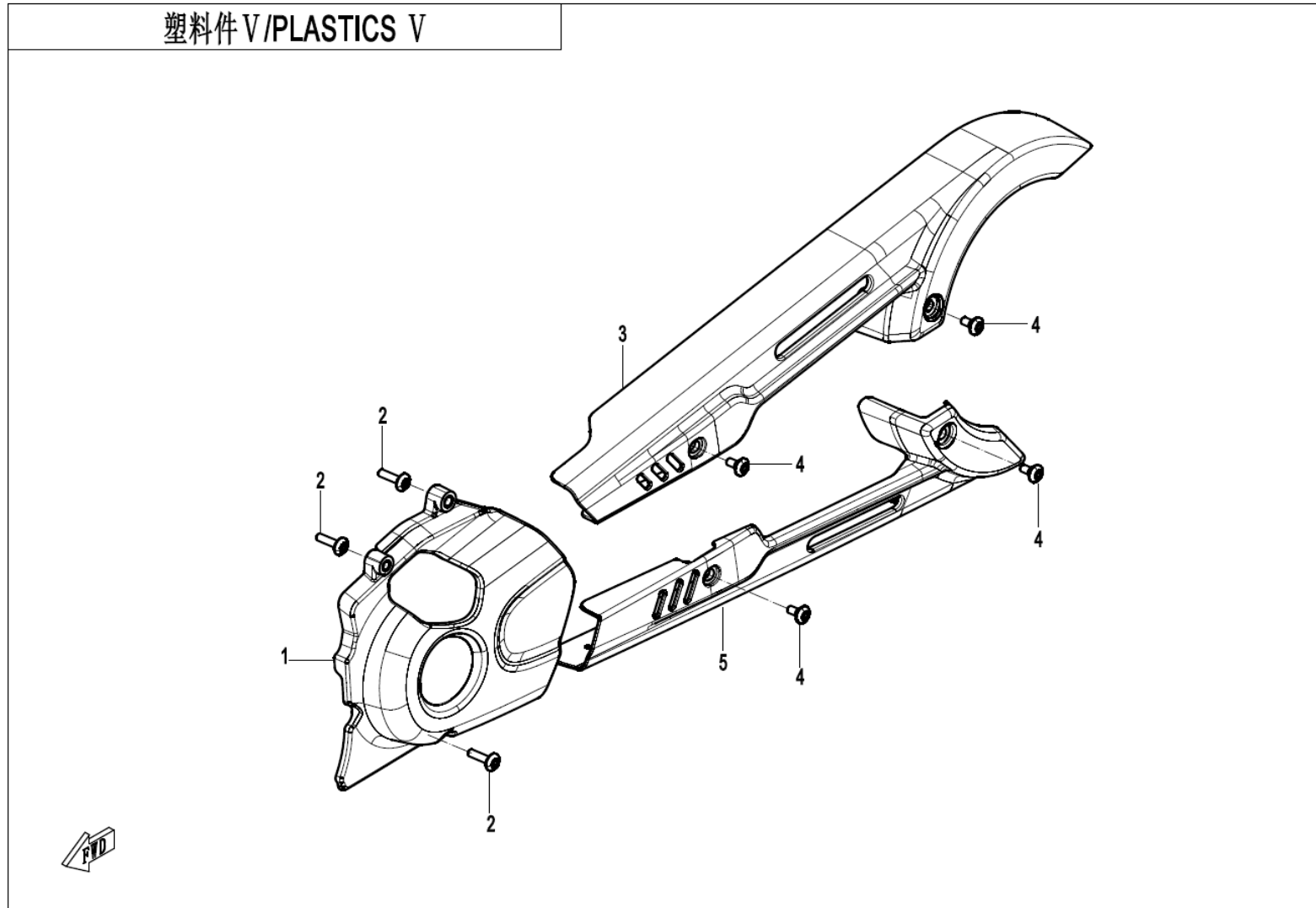

NO.	CODE	EN DESCRIPTION	QTY	REMARKS
F04-5-01	6AQV-000102-7100	SMALL SPROCKET GUARD	1	
F04-5-02	6WWV-047002-5000	INNER HEX SCREW M6x25	3	
F04-5-03	6AQV-040701-7100	BELT UPPER GUARD	1	
F04-5-04	6WWV-046602-5000	INNER HEX STEPPED SCREW M6x14	4	
F04-5-05	6AQV-040702-7100	BELT LOWER GUARD	1	

塑料件VI/PLASTICS VI

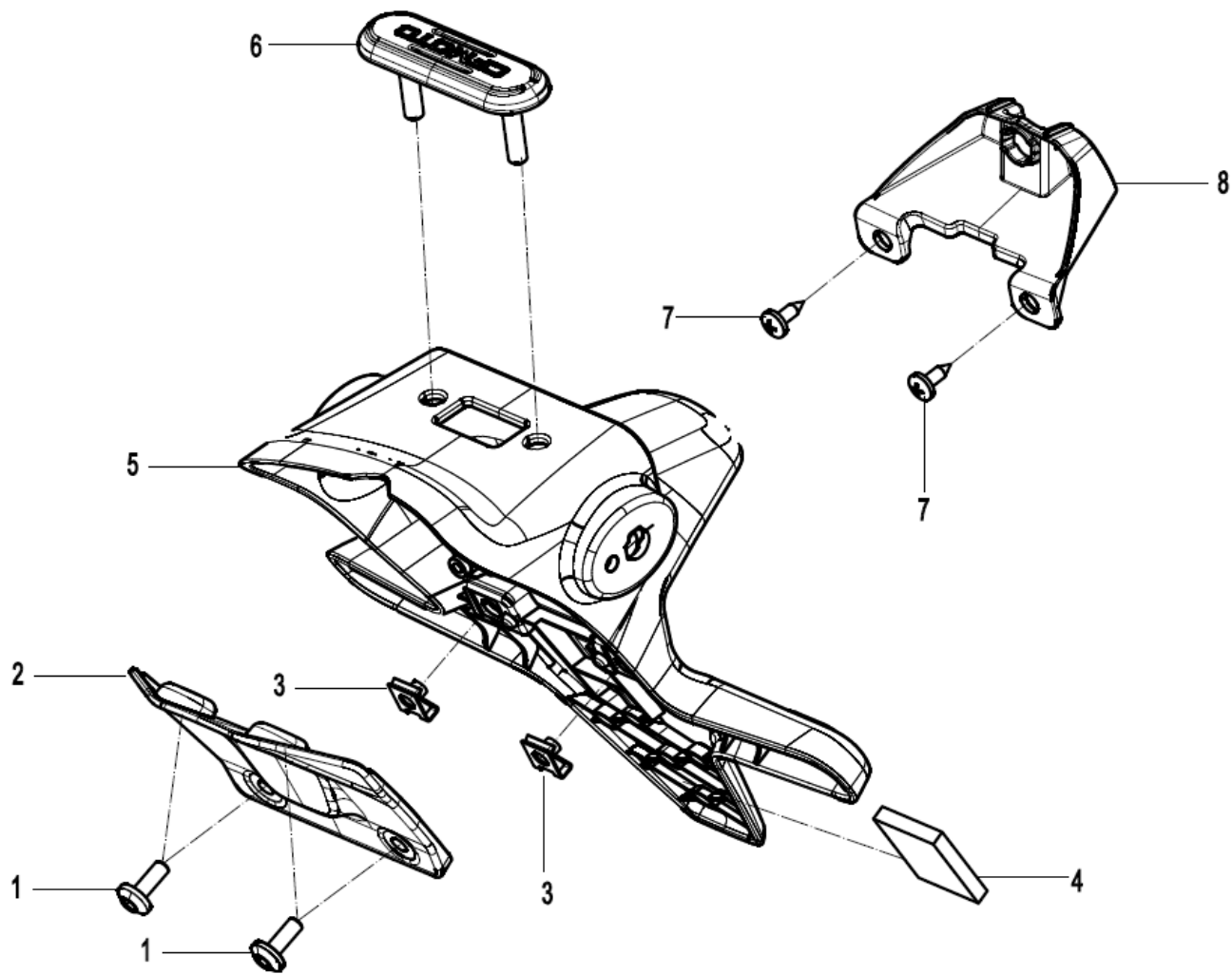

NO.	CODE	EN DESCRIPTION	QTY	REMARKS
F04-6-01	6WWV-047102-5000	INNER HEX SCREW M5x14	4	
F04-6-02	6AQV-040802-7100	REAR FENDER DECO COVER	1	
F04-6-03	6KM#-040081-8000-M1	NUT CLIP M5	2	
F04-6-04	6NT1-041510	BUCKLE ASSY	1	
F04-6-05	6AQV-040801-7100-10	"REAR FENDER	1	
F04-6-06	6AQV-040805-7100	PLUG,REAR FENDER	1	
F04-6-07	30110-421130010	SELF-TAPPING SCREW ST4.2X13	2	
F04-6-08	6AQV-040803-7100	LICENSE LIGHT BRACKET	1	

前悬架/Front Suspension

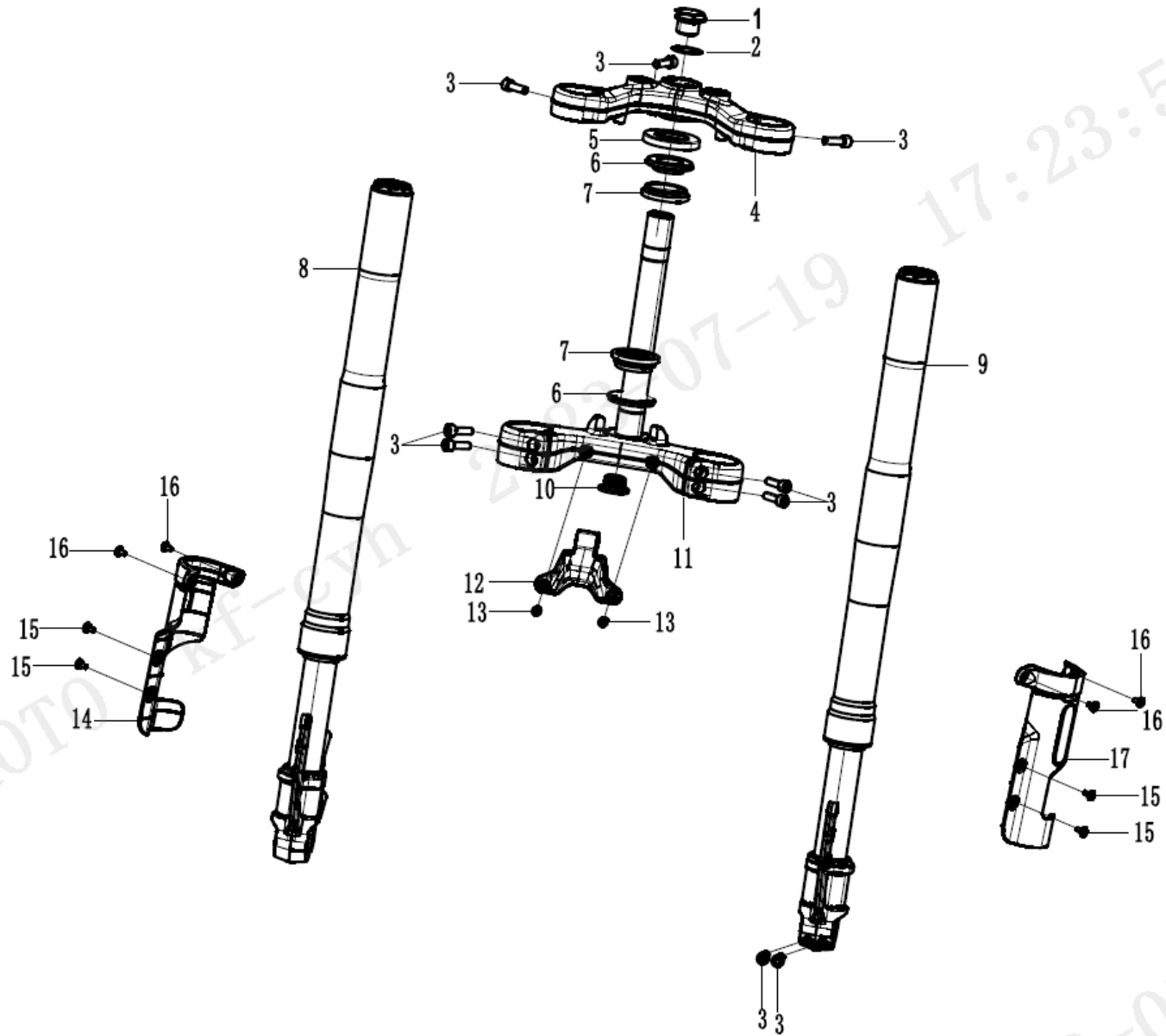

NO.	CODE	EN DESCRIPTION	QTY	REMARKS
F05-V1-01	6L30-050002	LOCK SCREW, UPPER TRIPLE CLAMP	1	
F05-V1-02	6WWV-050005-5000	WASHER	1	
F05-V1-03	30102-080025870	INNER HEX SCREW M8x25	9	
F05-V1-04	6AQV-050001-7101	UPPER TRIPLE CLAMP	1	
F05-V1-05	6L30-050003	DUST-PROOF COVER	1	
F05-V1-06	6AQV-050010-1000	ANTI-DUST RING	2	
F05-V1-07	6L30-050200	STEERING BEARING ASSY	2	
F05-V1-08	6AQV-050600-7103-M2	FRONT RH SHOCK ABSORBER	1	
F05-V1-09	6AQV-050500-7103-M2	FRONT LH SHOCK ABSORBER	1	
F05-V1-10	6L30-050004	PLUG, FRONT FORK	1	
F05-V1-11	6AQV-0503C0	LOWER TRIPLE CLAMP ASSY	1	
F05-V1-12	6AQV-050350-7100	HEADLIGHT BRACKET	1	
F05-V1-13	30102-060016870	SCREW M6x16	2	
F05-V1-14	6AQV-050012-7100	FRONT SHOCK RH DECO GUARD	1	
F05-V1-15	6WWV-046602-5000	INNER HEX STEPPED SCREW M6x14	4	
F05-V1-16	6WWV-046702-5000	INNER HEX SCREW M6x12	4	
F05-V1-17	6AQV-050011-7100	FRONT SHOCK LH DECO GUARD	1	

后悬挂总成/REAR SUSPENSION ASSY

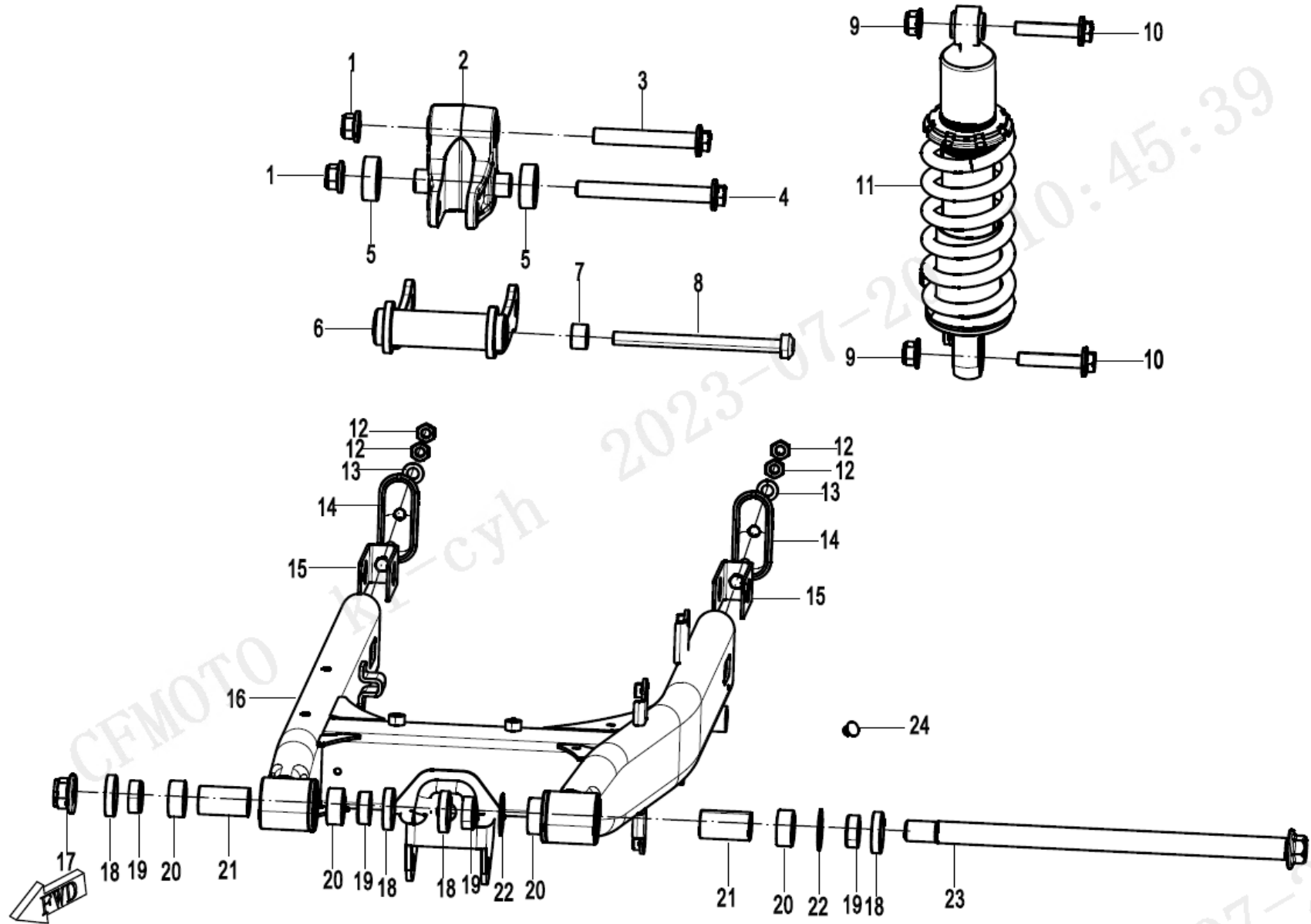

NO.	CODE	EN DESCRIPTION	QTY	REMARKS
F06-01	30204-122810	NUT M12X1.25	2	
F06-02	6AQV-060550-1000	A-SHAPE SWING ARM ASSY	1	
F06-03	6AQV-060008-1002	A-SHAPE SWING ARM BOLT M12X80	1	
F06-04	30024-122110110	BOLT	1	
F06-05	6AQV-060504-1000	RETAINER	2	
F06-06	6AQV-060600-1001	TIE ROD	1	
F06-07	6AQV-060005-1000	SPACER, TIE ROD	1	
F06-08	6AQV-060009-1002	TIE ROD BOLT M10X130	1	
F06-09	30204-102110	NUT M10X1.25	2	ALT:- 30204-102810
F06-10	6AQV-060004-1002	REAR SHOCK ABSORBER BOLT M10X50	2	
F06-11	6AQV-060100-7100-M2	REAR SHOCK ABSORBER	1	
F06-12	30200-080810	NUT M8	4	
F06-13	30306-080112	WASHER 8	2	
F06-14	6AQV-060021-7100-0BP00	GUARD, CHAIN ADJUSTER (MAUD SPIRIT BLACK)	2	
F06-15	6AQV-060020-7100	CHAIN ADJUSTER ASSY	2	
F06-16	6AQV-060300-7100-0BP00	REAR FORK ASSY (MAUD SPIRIT BLACK)	1	
F06-17	6AQV-060006-1000-M1	NUT M16X1.5	1	
F06-18	6WWV-060030-5000-10	OIL SEAL	4	
F06-19	6WWV-060002-5000	BUSHING, REAR SWING ARM	4	
F06-20	30403-02280	NEEDLE BEARING	4	
F06-21	6WWV-060003-5000	LINER, REAR SWING ARM	2	
F06-22	6WWV-060004-5000	WASHER, REAR SWING ARM	2	
F06-23	6AQV-060001-7100	REAR FORK SHAFT	1	
F06-24	6KM#-100002-8000	PLUG	4	

前轮杆/FRONT WHEEL

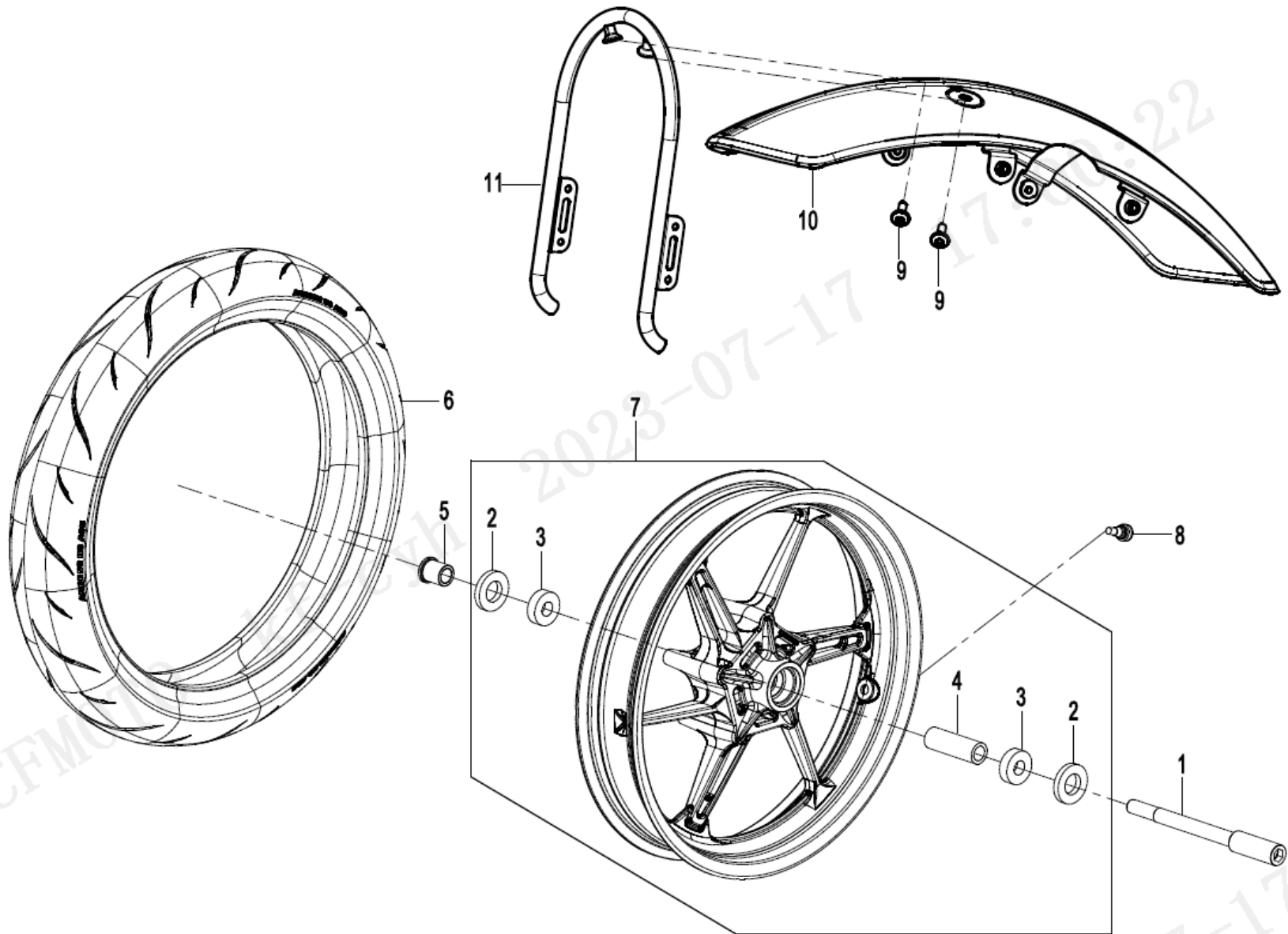

NO.	CODE	EN DESCRIPTION	QTY	REMARKS
F07-01	6AQV-070001-7100	FRONT WHEEL SHAFT	1	
F07-02	6AQV-070200-1000-20	OIL SEAL	2	
F07-03	30400-01785	BEARING	2	
F07-04	6AQV-070202-7100	FRONT RIM MIDDLE SPACER	1	
F07-05	6AQV-070002-1000	FRONT WHEEL SHAFT BUSHING	1	
F07-06	30705-1601	TIRE	1	
F07-07	6AQV-070200-7100-0BV00	FRONT RIM ASSY	1	
F07-08	5190-070030-1000	VALVE, INFLATION	1	
F07-09	A000-040702	INNER HEX SCREW M6x12	2	ALT:- 6KM#-040702-8000
F07-10	6AQV-070010-7100-0BM00	FRONT FENDER ASSY	1	
F07-11	6AQV-070020-7100-0BM00	FRONT FENDER TUBE ASSY	1	

液压制动总成 / HYDRAULIC BRAKE ASSY

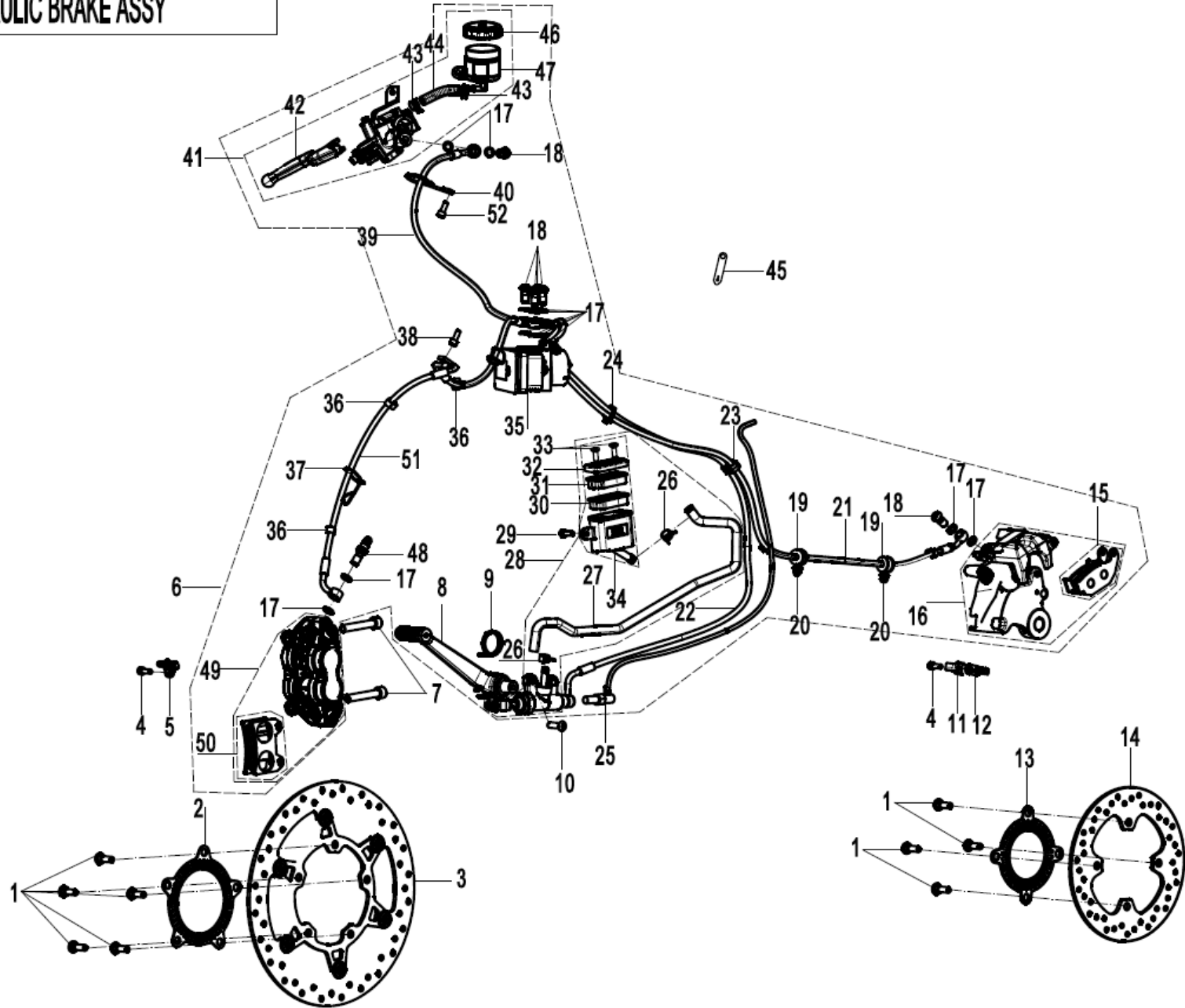

NO.	CODE	EN DESCRIPTION	QTY	REMARKS
F08-01	6KJ0-080005	FRONT BRAKE DISC BOLT	9	
F08-02	6AQV-080002-1000	"FRONT GEAR RING	1	
F08-03	6AQV-080001-1000-M1	FRONT BRAKE DISC	1	
F08-04	30102-060016870	SCREW M6x16	2	
F08-05	6AQV-080004-1000-M2	FRONT SPEED SENSOR	1	
F08-06	6AQV-081000-7102	MAB HYDRAULIC BRAKE ASSY	1	
F08-07	30102-102060810	SCREW M10x1.25x60	2	
F08-08	6AQV-080300-7100	REAR BRAKE PEDAL ASSY	1	
F08-09	6AQV-080400-1000	SPRING	1	
F08-10	30121-080025160	SCREW M8X25	1	
F08-11	6AQV-081003-1000	WIRE CLIP, REAR SPEED SENSOR	1	
F08-12	6AQV-080005-1000-M2	REAR RPM SENSOR	1	
F08-13	6NTG-080009	REAR GEAR RING	1	
F08-14	6AQV-080006-1000	REAR BRAKE DISC	1	
F08-15	6KM0-0911B0	REAR BRAKE PAD ASSY	1	
F08-16	6AQV-081710-1001-M1	REAR BRAKE CALIPER	1	
F08-17	6AQV-081000-7100-20	WASHER	16	
F08-18	6GU#-081000-6000-23	BANJO BOLT 2	6	
F08-19	6KM#-080002-8000	RUBBER OIL HOSE CLIP	2	
F08-20	A000-050015	WIRE CLIP, FRONT BRAKE FLUID HOSE	2	
F08-21	6AQV-081900-7100	REAR BRAKE FLUID INTAKE PIPE	1	
F08-22	6AQV-081800-7102	REAR BRAKE FLUID OUTLET PIPE	1	
F08-23	6L30-080006	WIRE CLIP 2, BRAKE FLUID HOSE	1	
F08-24	8010-150003	TIE 5X250	4	
F08-25	6AQV-081070-7100-M1	REAR BRAKE LIGHT SWITCH	1	
F08-26	6KM0-091215-20000	HOSE CLIP 1	2	
F08-27	6AQV-081400-7100-24	RESERVOIR PIPE	1	
F08-28	6AQV-081400-7100-M1	REAR BRAKE MASTER CYLINDER ASSY	1	
F08-29	6WWV-046802-5000	INNER HEX SCREW M6x16	1	
F08-30	6AQV-081410-1000-23	BACKING PLATE, RESERVOIR TANK	1	
F08-31	6AQV-081410-1000-22	GASKET, RESERVOIR TANK	1	
F08-32	6AQV-081410-1000-24	RESERVOIR TANK COVER	1	

NO.	CODE	EN DESCRIPTION	QTY	REMARKS
F08-33	6AQV-081410-1000-25	SCREW, RESERVOIR TANK COVER	2	
F08-34	6AQV-081410-1000-21	RESERVOIR TANK	1	
F08-35	6AQV-081300-7100-M1	ABS CONTROLLER	1	
F08-36	6KJ0-080003-00001	"BRAKE HOSE CLIP	6	
F08-37	6AQV-081603-7100	CLIP,FRONT BRAKE FLUID PIPE	1	
F08-38	30102-060012810	SCREW M6X12	1	
F08-39	6AQV-081500-7100	FRONT BRAKE FLUID OUTLET PIPE	1	
F08-40	6AQV-081601-1002	WIRE CLIP, FLUID INLET HOSE	1	
F08-41	6AQV-081100-7100-M1	FRONT BRAKE MASTER CYLINDER ASSY	1	
F08-42	6AQV-081110-1000-47	BRAKE LEVER	1	
F08-43	6AQV-081110-1000-46	CLAMP	2	
F08-44	6AQV-081100-4000-27	PIPE	1	
F08-45	6KJ0-100002	CLUTCH PULL BINDING	2	
F08-46	6AQV-081110-1000-53	RESERVOIR TANK	1	
F08-47	6AQV-081110-1001-54	CAP, FLUID RESERVOIR	1	
F08-48	6GU#-081000-6000-22	BANJO BOLT 1	1	
F08-49	6AQV-081200-7100	FRONT RH BRAKE CALIPER ASSY	1	
F08-50	6AQV-081200-71A0	FRONT BRAKE PAD ASSY	1	
F08-51	6AQV-081600-7102	FRONT BRAKE FLUID INTAKE PIPE	1	
F08-52	6WWV-046702-5000	INNER HEX SCREW M6x12	1	

转向系统/STEERING SYSTEM

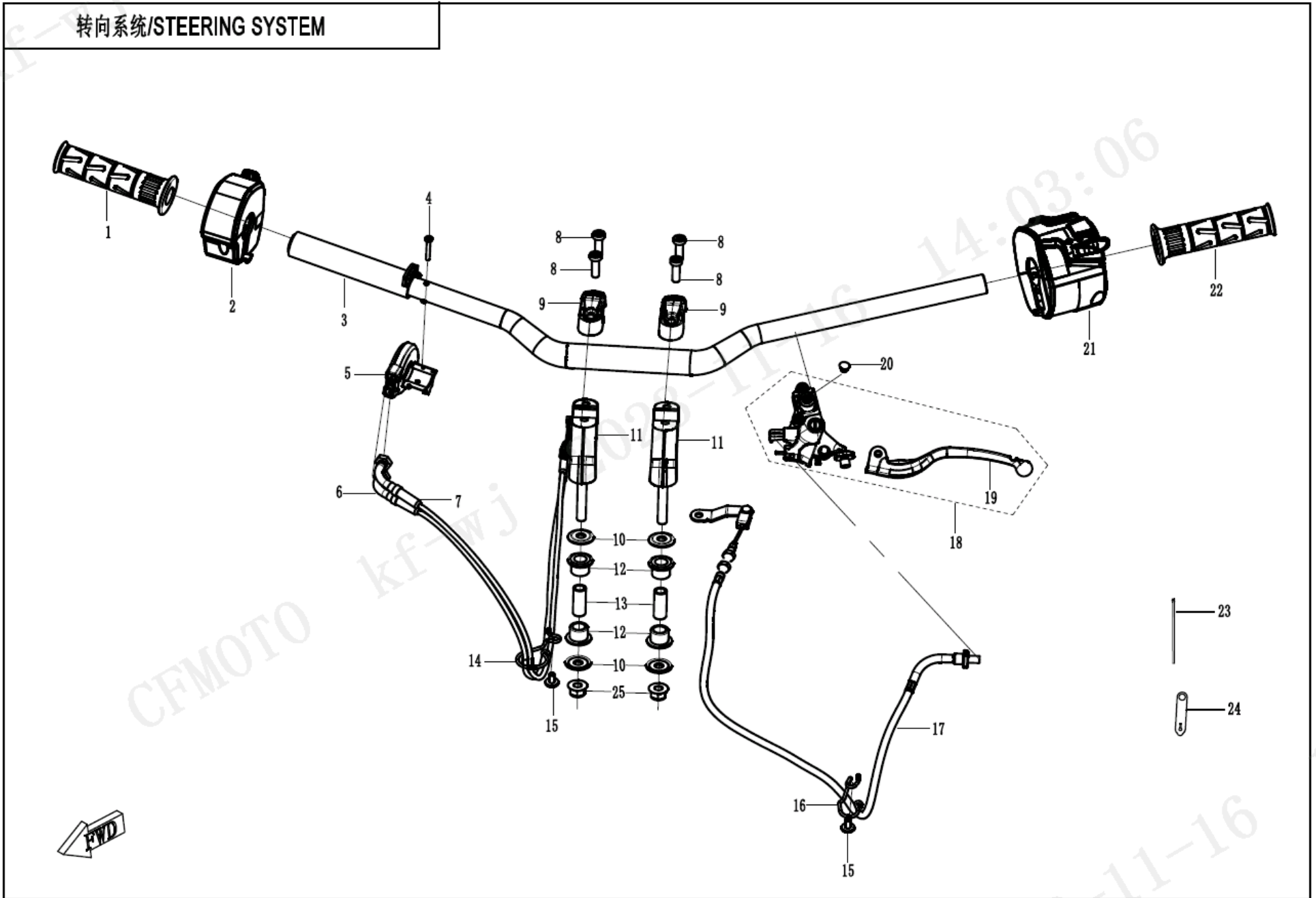

NO.	CODE	EN DESCRIPTION	QTY	REMARKS
F10-01	A000-100010-20000	RH HAND GRIP ASSY	1	
F10-02	6AQV-167000-7100	RH HANDLEBAR SWITCH ASSY	1	
F10-03	6AQV-100100-7100	HANDLEBAR PIPE	1	
F10-04	30105-040030410	SCREW M4X30	1	
F10-05	6AQV-100700-1003	THROTTLE LEVER	1	
F10-06	6AQV-100500-7100	ADJUSTABLE THROTTLE CABLE	1	
F10-07	6AQV-100400-7100	THROTTLE CABLE	1	
F10-08	30102-080025870	INNER HEX SCREW M8x25	4	
F10-09	6AQV-100003-7100	HANDLEBAR COVER	2	
F10-10	6KJ0-050005	WASHER	4	
F10-11	6AQV-100031-7100	HANDLEBAR BRACKET ASSY	2	
F10-12	6KJ0-050004	DAMPER RUBBER, UPPER TRIPLE CLAMP	4	
F10-13	6KJ0-050006-00001	LINER, UPPER TRIPLE CLAMP	2	
F10-14	6AQV-100602-7101	HANDLEBAR RH CABLE HOOK	1	
F10-15	6WWV-046702-5000	INNER HEX SCREW M6x12	2	
F10-16	6AQV-100601-7101	HANDLEBAR LH CABLE HOOK	1	
F10-17	6AQV-100600-7100	CLUTCH CABLE	1	
F10-18	6WWV-100200-5003	CLUTCH LEVER ASSY	1	
F10-19	6WWV-100201-5000	CLUTCH LEVER	1	
F10-20	6KM#-100002-8000	PLUG	1	
F10-21	6AQV-166000-7100	LH HANDLEBAR SWITCH ASSY	1	
F10-22	A000-100001-10000	LH HAND GRIP	1	
F10-23	801F-100101	TIE BAND	1	
F10-24	6KJ0-100002	CLUTCH PULL BINDING	2	
F10-25	30204-102810	NUT M10X1.25	2	

后轮/REAR WHEEL

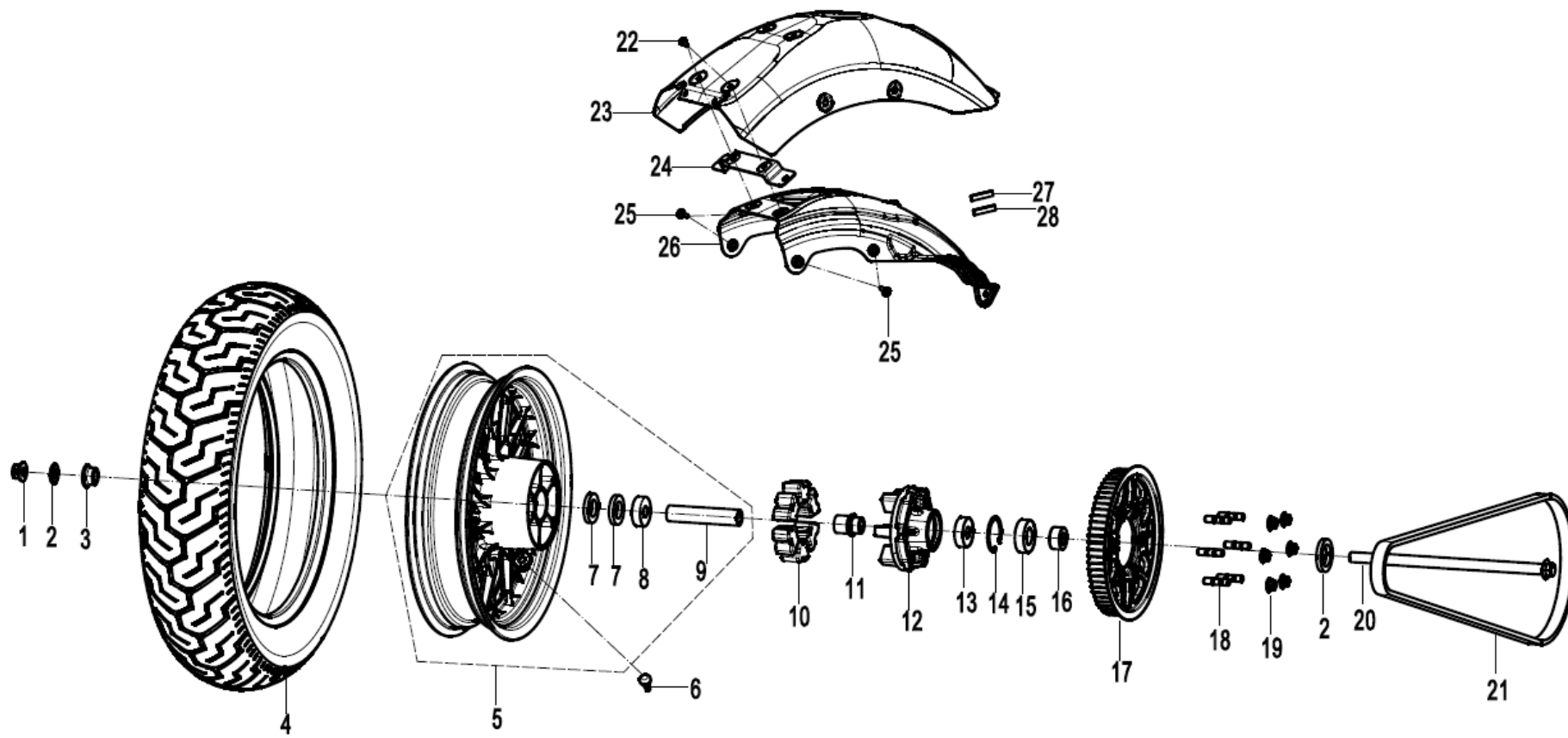

NO.	CODE	EN DESCRIPTION	QTY	REMARKS
F11-01	6AQV-060006-1000-M1	NUT M16X1.5	1	
F11-02	6AQV-110033-7100	BRAKE REAR WHEEL SHAFT PLAIN WASHER	2	
F11-03	6AQV-110004-1000	REAR WHEEL RH SHAFT BUSHING	1	
F11-04	30705-1602	TIRE	1	
F11-05	6AQV-110200-7100-0BV00	REAR RIM ASSY	1	
F11-06	5190-070030-1000	VALVE, INFLATION	1	
F11-07	30400-01784	BEARING	2	
F11-08	30500-027800N	OIL SEAL	1	
F11-09	6AQV-110202-7100	REAR RIM MIDDLE SPACER	1	
F11-10	6AQV-110004-7100	DRIVEN PULLEY SEAT DAMPER	6	
F11-11	6AQV-110003-7100	DRIVEN PULLEY SEAT SHAFT SLEEVE	1	
F11-12	6AQV-110501-7100	DRIVEN PULLEY SEAT	1	
F11-13	30400-02503	BEARING	1	
F11-14	30800-05205	CIRCLIP FOR HOLE	1	
F11-15	30501-035800N	OIL SEAL	1	
F11-16	6AQV-110003-1000	REAR WHEEL LH SHAFT BUSHING	1	
F11-17	6AQV-110009-7101-M1-0BP00	DRIVEN PULLEY	1	
F11-18	6AQV-110034-7100	"DRIVEN PULLEY SEAT STUD	6	
F11-19	30204-102810	NUT M10X1.25	6	
F11-20	6AQV-110001-7100	REAR WHEEL SHAFT	1	
F11-21	6AQV-110008-7100-M1	SYNCHRONOUS BELT	1	
F11-22	30006-060016810	BOLT M6X16	2	ALT:- 30006-060016870
F11-23	6AQV-110021-7101-0BM00	REAR FENDER OUTER PLATE	1	
F11-24	6AQV-030120-7100	SEAT SUPPORT	1	
F11-25	5HY0-220113	BOLT M8x20	4	
F11-26	6AQV-110010-7101	REAR FENDER INNER PLATE ASSY	1	
F11-27	6AQV-110031-7100	FENDER RUBBER 1	6	
F11-28	6AQV-110032-7100	FENDER RUBBER 2	8	

油箱/FUEL TANK

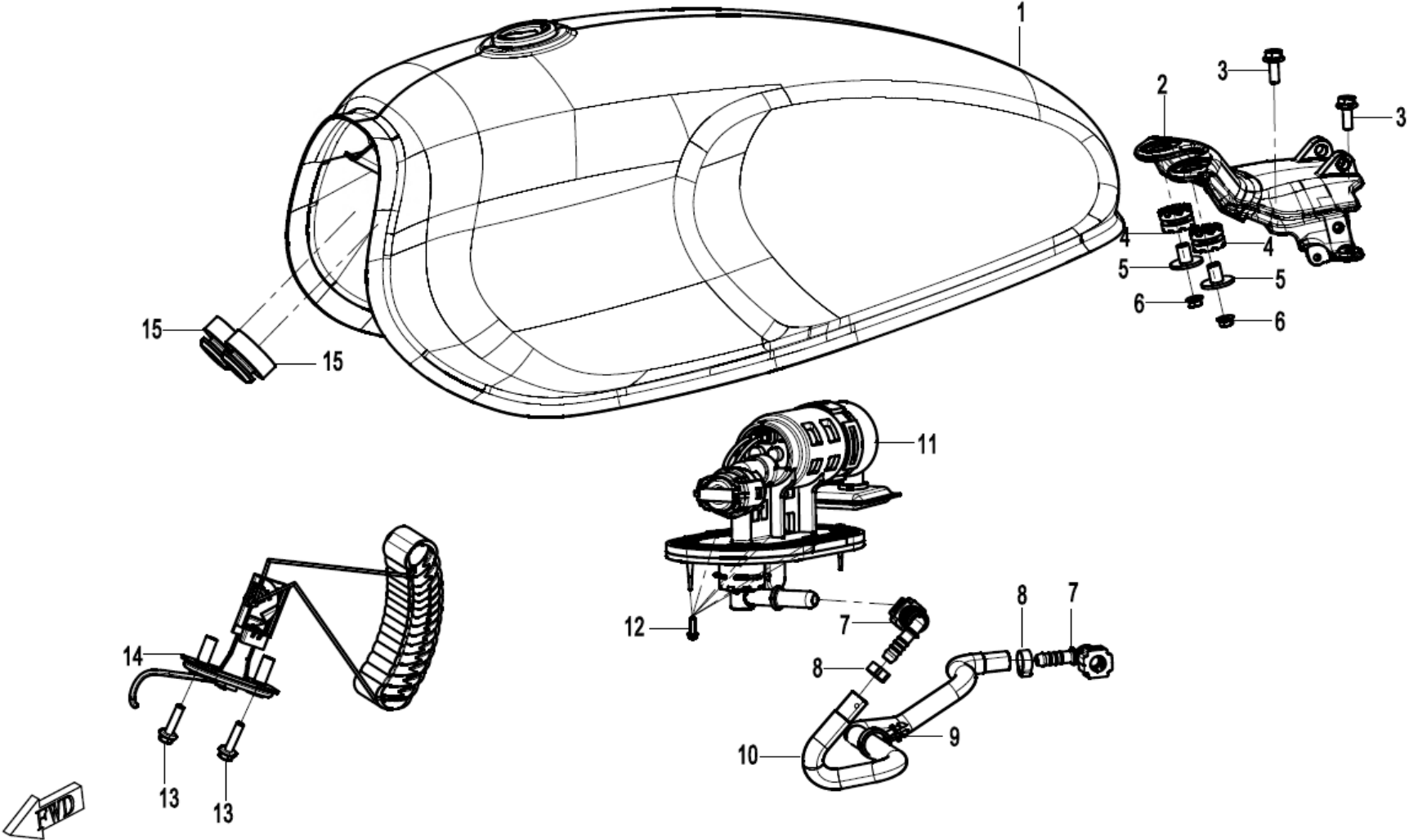

NO.	CODE	EN DESCRIPTION	QTY	REMARKS
F12-01	6AQV-121000-7100-0BM00	FUEL TANK ASSY (NEBULA BLACK)	1	
F12-01	6AQV-122000-7100-10-0W500	FUEL TANK WITH DECAL ASSY. (SILVER+RED)	1	
F12-02	6AQV-120001-7100-0BP00	FUEL TANK REAR LOWER BRACKET (MAUD SPIRIT BLACK)	1	
F12-03	30006-060016810	BOLT M6X16	2	ALT:- 30006-060016870
F12-04	5020-031001	RUBBER SLEEVE, FRONT LICENSE BRACKET	2	
F12-05	5020-031002	RUBBER SLEEVE LINER, FRONT LICENSE BRACKET	2	
F12-06	30204-060810	NUT M6	2	
F12-07	6090-120210	QUICK JOINT	2	
F12-08	6070-120400	CLAMP Dia.14.5	2	
F12-09	A000-050015	WIRE CLIP, FRONT BRAKE FLUID HOSE	1	
F12-10	6AQV-120030-7100	HIGH-PRESSURE FUEL HOSE ASSY	1	
F12-11	6AQV-150900-7100	FUEL PUMP ASSY	1	
F12-12	30006-050020810	BOLT M5X20	6	
F12-13	6FI3-170500-00001	FUEL LEVEL SENSOR BOLT	2	
F12-14	6AQV-170200-7100-M1	FUEL LEVEL SENSOR	1	
F12-15	6AQV-120002-7100	"CUSHION RUBBER WAHSER	2	

座墊/SEAT

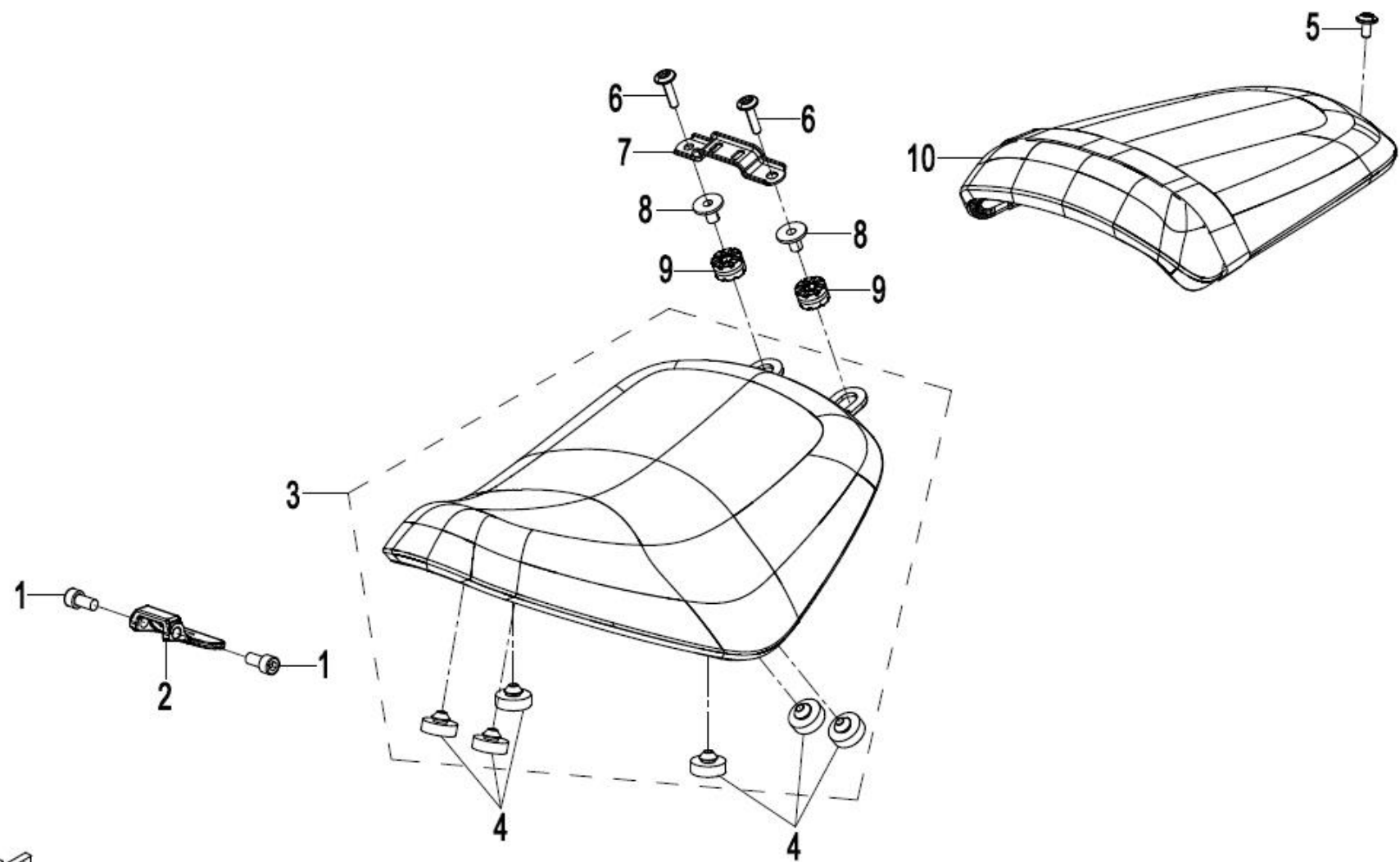

NO.	CODE	EN DESCRIPTION	QTY	REMARKS
F13-V2-01	30102-080016810	SCREW GB/T70.1_M8×16	2	
F13-V2-02	6AQV-130001-7100	FRONT SEAT BRACKET	1	
F13-V2-03	6AQV-130100-7103	FRONT SEAT ASSY (RUBY RED)	1	
F13-V2-03	6AQV-130100-7101-10	FRONT SEAT ASSY (NEBULA BLACK)	1	
F13-V2-04	6KM0-130205	CUSHION RUBBER WAHSER	6	
F13-V2-05	6WWV-046702-5000	INNER HEX SCREW M6x12	1	
F13-V2-06	6NTG-200424	INNER HEX SCREW M6x25	2	
F13-V2-07	6AQV-130002-7101	SEAT BRACKET	1	
F13-V2-08	6KM0-120010	T-TYPE BUSHING ASSY	2	
F13-V2-09	5020-031001	RUBBER SLEEVE, FRONT LICENSE BRACKET	2	
F13-V2-10	6AQV-130200-7102	REAR SEAT ASSY (RUBY RED)	1	
F13-V2-10	6AQV-130200-7101-10	REAR SEAT ASSY (NEBULA BLACK)	1	

F14 脚蹬 FOOTREST

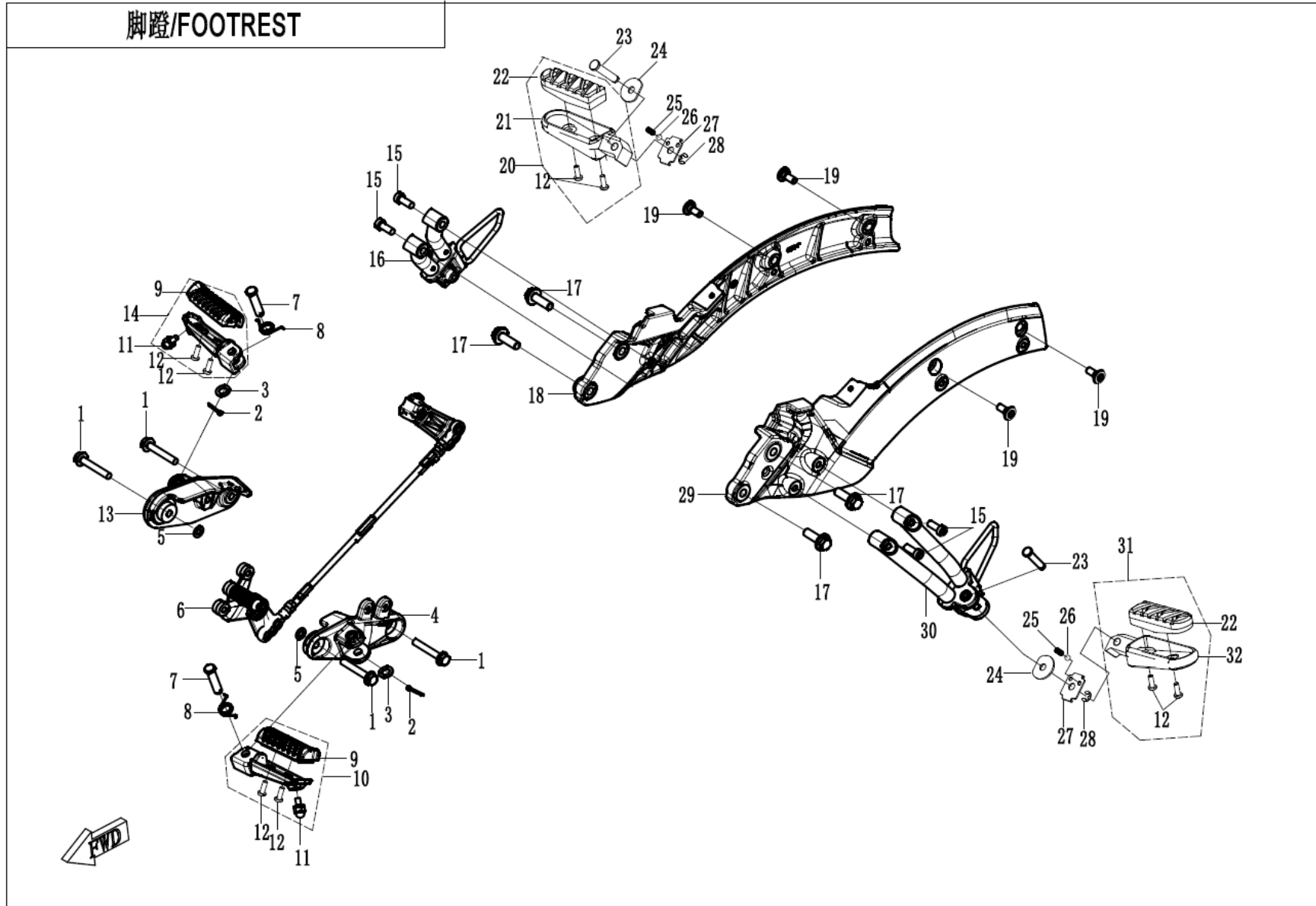

NO.	CODE	EN DESCRIPTION	QTY	REMARKS
F14-01	30006-080050870	BOLT	4	
F14-02	30903-0322210	COTTER PIN 3.2X22	2	

NO.	CODE	EN DESCRIPTION	QTY	REMARKS
F14-03	30300-100112	WASHER 10	2	
F14-04	6AQV-140600-7101	FRONT LH FOOTREST BRACKET	1	
F14-05	0180-334004	GASKET 8.2x15x1.5	2	
F14-06	6AQV-141000-7100	GEARSHIFT ROD CONNECTING ASSY	1	
F14-07	6WWV-140141-5000	PIN SHAFT	2	
F14-08	A000-140103-20000	SPRING	2	
F14-09	6KMV-140170-8100	FOOTREST RUBBER	2	
F14-10	6KWV-140800-1000-OBP00	LH FRONT FOOTREST SEAT ASSY (MAUD SPIRIT BLACK)	1	
F14-11	6GU#-140202-6000	LIMIT BOLT	2	
F14-12	30105-050014470	SCREW M5X14	8	
F14-13	6AQV-140700-7100	RH FRONT FOOTREST BRACKET	1	
F14-14	6KWV-140900-1000-OBP00	RH FRONT FOOTREST SEAT ASSY (MAUD SPIRIT BLACK)	1	
F14-15	30102-080020870	SCREW M8X20	4	
F14-16	6AQV-140040-7100-OBP00	RH REAR FOOTREST BRACKET ASSY (MAUD SPIRIT BLACK)	1	
F14-17	30006-102030810	BOLT M10X1.25X30	4	
F14-18	6AQV-146000-7101-OBP00	RH REAR FENDER BRACKET (MAUD SPIRIT BLACK)	1	
F14-19	5HY0-220113	BOLT M8x20	4	
F14-20	6GU#-1400B0-6000-OBP00	RUBBER, RH REAR FOOTREST BOARD (MAUD SPIRIT BLACK)	1	
F14-21	6GU#-140051-6000-OBP00	REAR RH FOOTREST SEAT (MAUD SPIRIT BLACK)	1	
F14-22	6GU#-140080-6000	RUBBER, REAR FOOTREST BOARD	2	
F14-23	A000-140142	PIN SHAFT Dia 8	2	
F14-24	A000-140106	LOCATING GASKET 2	2	
F14-25	5190-037813	SPRING	2	
F14-26	5190-037814	STEEL BALL	2	
F14-27	A000-140104	LOCATING GASKET 1	2	
F14-28	30802-00603	CIRCLIP 6	2	
F14-29	6AQV-145000-7101-OBP00	LH REAR FENDER BRACKET (MAUD SPIRIT BLACK)	1	
F14-30	6AQV-140030-7100-OBP00	LH REAR FOOTREST BRACKET ASSY (MAUD SPIRIT BLACK)	1	
F14-31	6GU#-1400A0-6000-OBP00	RUBBER, LH REAR FOOTREST BOARD (MAUD SPIRIT BLACK)	1	
F14-32	6GU#-140041-6000-OBP00	REAR LH FOOTREST SEAT (MAUD SPIRIT BLACK)	1	

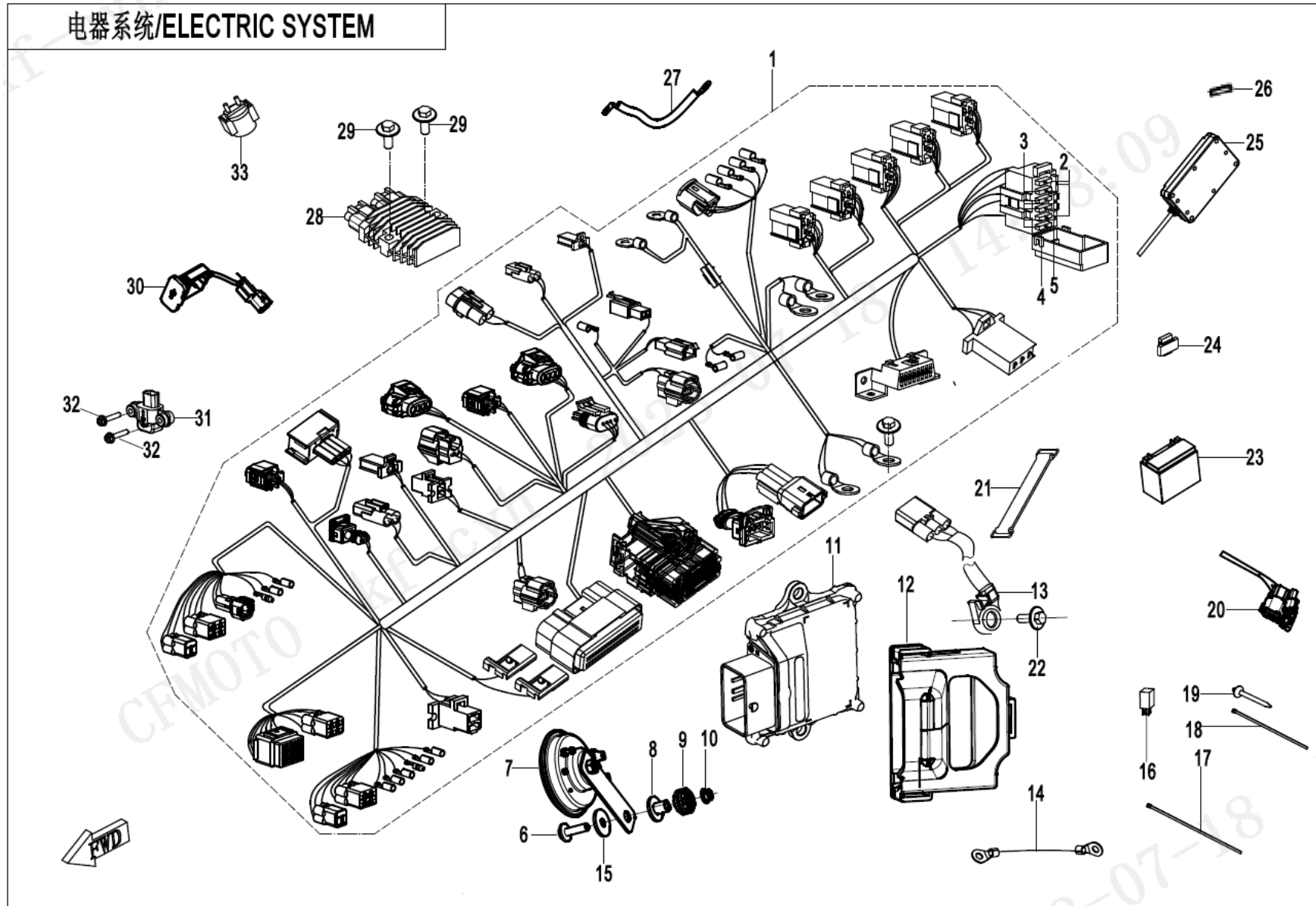

NO.	CODE	EN DESCRIPTION	QTY	REMARKS
F15-01	6AQV-150100-7101	MAIN CABLE	1	
F15-02	806A-151302	FUSE 10A	2	

NO.	CODE	EN DESCRIPTION	QTY	REMARKS
F15-03	806A-151307	25A FUSE	1	
F15-04	806A-151305	FUSE 15A	3	
F15-05	8010-151301	FUSE 5A	2	
F15-06	6WWV-047002-5000	INNER HEX SCREW M6x25	1	
F15-07	6FIV-150600-7000	HORN	1	
F15-08	9060-180029	RADIATOR SLEEVE TUBE	1	
F15-09	6WWV-030019-5000	CUSHION SLEEVE	1	
F15-10	30204-060870	NUT M6	1	
F15-11	6AQV-001000-7100	ECU ASSY	1	
F15-12	6AQV-001300-7100	ECU RUBBER	1	
F15-13	6KMV-151500-3000	SIDE STAND SWITCH	1	
F15-14	6AQV-150310-7100	STARTER MOTOR POSITIVE	1	
F15-15	30301-060470	WASHER 6	1	
F15-16	5BY4-150330	AUXILIARY RELAY	4	
F15-17	9010-150004	TIE	1	
F15-18	8010-150003	TIE 5X250	14	
F15-19	801F-100101	TIE BAND	1	
F15-20	6AQV-150176-7100	LICENSE LIGHT ADAPTER CABLE	1	
F15-21	9RHV-150700-1000	TIE BAND, BATTERY	1	
F15-22	8010-090005	BOLT M6x16	1	
F15-23	83200-0000-750006	BATTERY	1	
F15-24	6100-150500	RUBBER SLEEVE, FLASHER	2	
F15-25	SN1V-691100-1201-11	T-BOX	1	
F15-26	6AQV-110031-7100	FENDER RUBBER 1	2	
F15-27	6AQV-150420-7100	BATTERY NEGATIVE	1	
F15-28	6AQV-151000-1000	REGULATOR	1	
F15-29	30102-060025870	SCREW M6x25	1	
F15-30	FA8V-150600-1000-10	USB OUTPUT SOCKET ASSY	1	
F15-31	6KJ0-150600	SENSOR, ROLL-OVER	1	
F15-32	30006-050020810	BOLT M5X20	2	
F15-33	6AQV-150510-7100	STARTER RELAY	1	

灯具/LIGHT

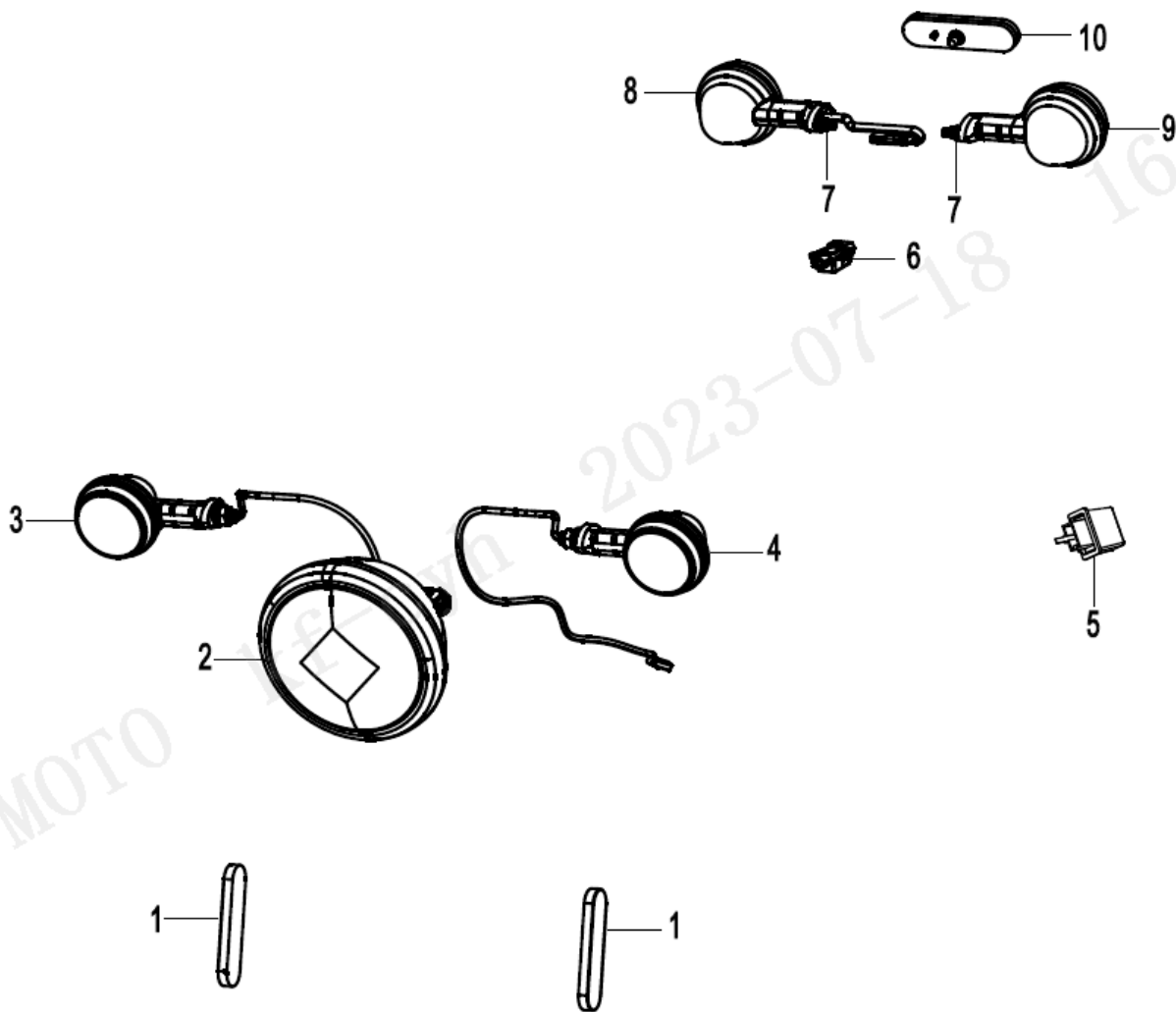

2023-07-18

NO.	CODE	EN DESCRIPTION	QTY	REMARKS
F16-01	6KM#-050030-8100	SIDE REFLECTOR	2	
F16-02	6AQV-160110-7100	HEADLIGHT	1	
F16-03	6AQV-160520-7100	RH FRONT TURN LIGHT ASSY	1	
F16-04	6AQV-160510-7100	LH FRONT TURN LIGHT ASSY	1	
F16-05	6AQV-161000-7100	FLASHER	1	
F16-06	6GUV-160600-6200	LICENSE LIGHT	1	
F16-07	30202-050110	NUT M5	4	
F16-08	6AQV-160540-7100	RH REAR TURN LIGHT ASSY	1	
F16-09	6AQV-160530-7100	LH REAR TURN LIGHT ASSY	1	
F16-10	9AWV-160910-2C01-M1	REAR REFLECTOR	1	

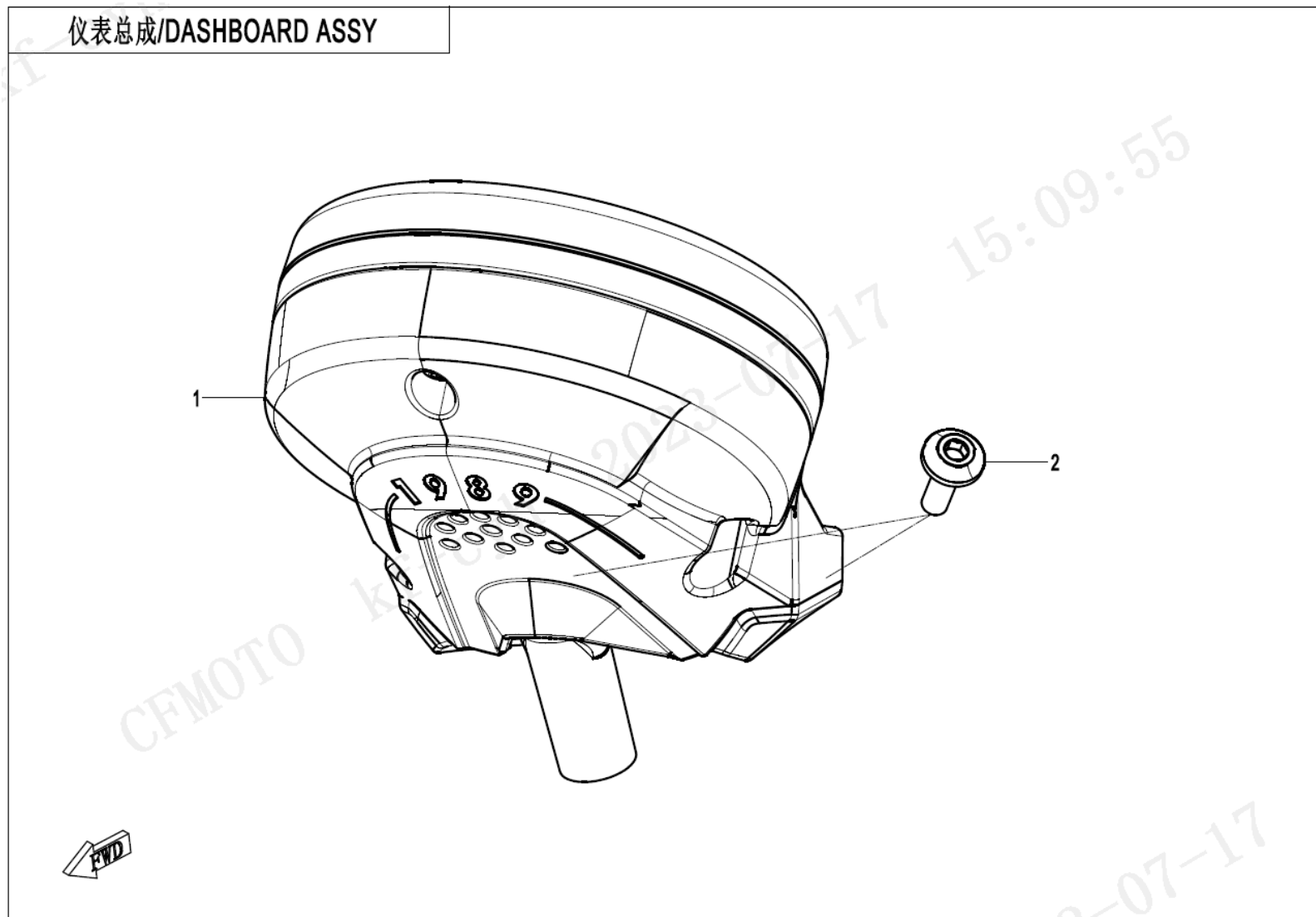

NO.	CODE	EN DESCRIPTION	QTY	REMARKS
F17-01	6AQV-171000-7100	DASHBOARD	1	
F17-02	30102-060020870	INNER HEX SCREW M6×20	2	

冷却系统总成/COOLING SYSTEM ASSY

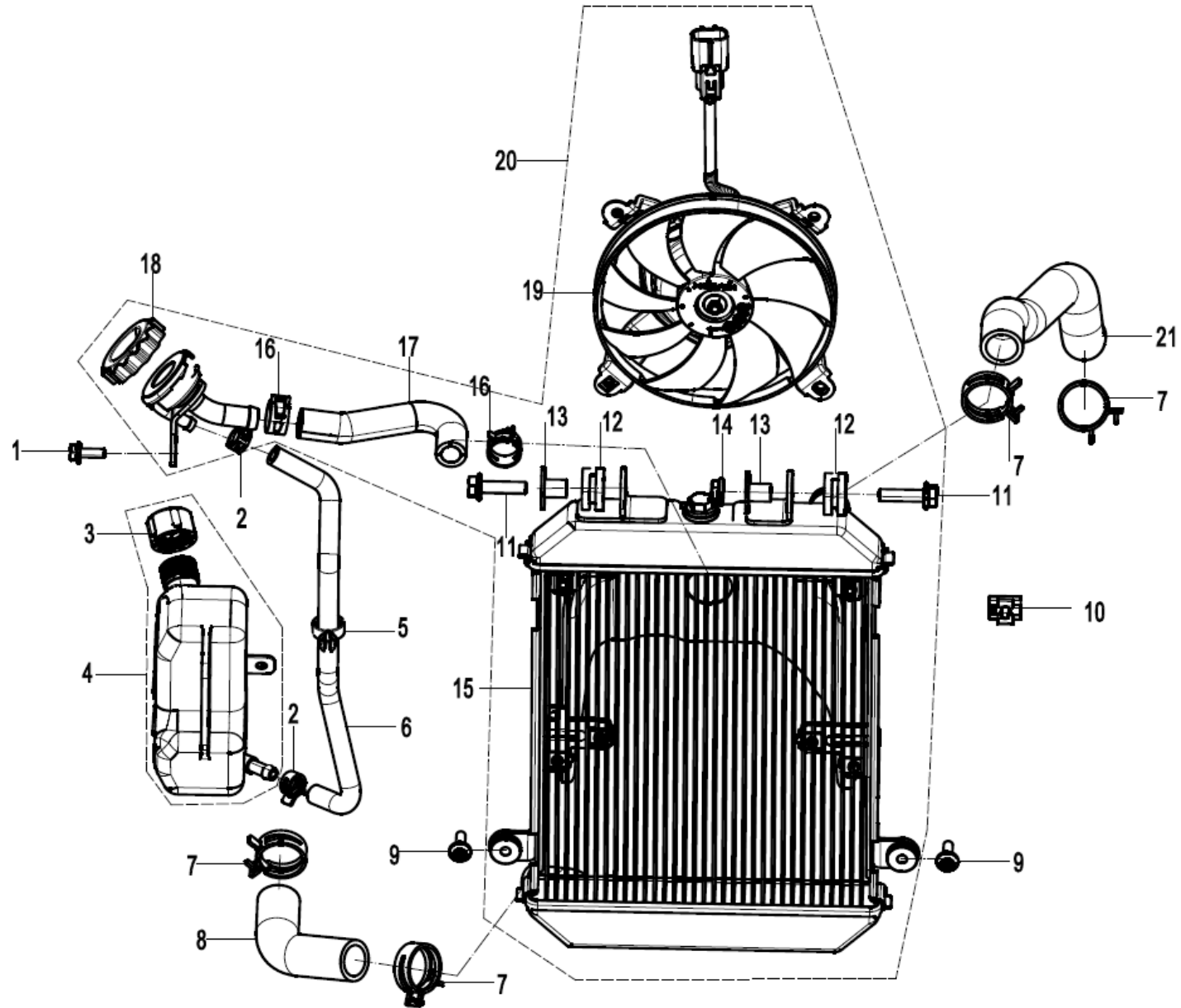

NO.	CODE	EN DESCRIPTION	QTY	REMARKS
F18-01	30006-060016810	BOLT M6X16	1	
F18-02	30601-212570	CLAMP	2	
F18-03	6AQV-180110-4000	RESERVOIR CAP ASSY	1	
F18-04	6AQV-180100-7100	RESERVOIR ASSY	1	
F18-05	A000-050015	WIRE CLIP, FRONT BRAKE FLUID HOSE	1	
F18-06	6AQV-180003-7100	CONNECTING PIPE, RESERVOIR	1	
F18-07	30601-229060	CLAMP	4	
F18-08	6AQV-180002-7100	RADIATOR WATER OUTLET HOSE	1	
F18-09	6WWV-047002-5000	INNER HEX SCREW M6x25	2	
F18-10	CFCV-CAC002-2000-M1	CLIP	1	
F18-11	30006-080030870	BOLT M8X30	2	
F18-12	A000-180005	RADIATOR SHOCK ABSORBER RUBBER 2	2	
F18-13	A000-180010-20000	RADIATOR RUBBER DAMPER 2 BUSHING	2	
F18-14	30202-080110	NUT	1	
F18-15	6AQV-181100-7101	RADIATOR ASSY	1	
F18-16	30601-220050	CLAMP B20	2	
F18-17	6AQV-181300-7100	TUBE	1	
F18-18	6AQV-181500-7100	FILLER CAP ASSY	1	
F18-19	6AQV-181200-7100	FAN MOTOR ASSY	1	
F18-20	6AQV-181000-7101	RADIATOR FAN ASSY	1	
F18-21	6AQV-180001-7100	RADIATOR WATER INLET HOSE	1	

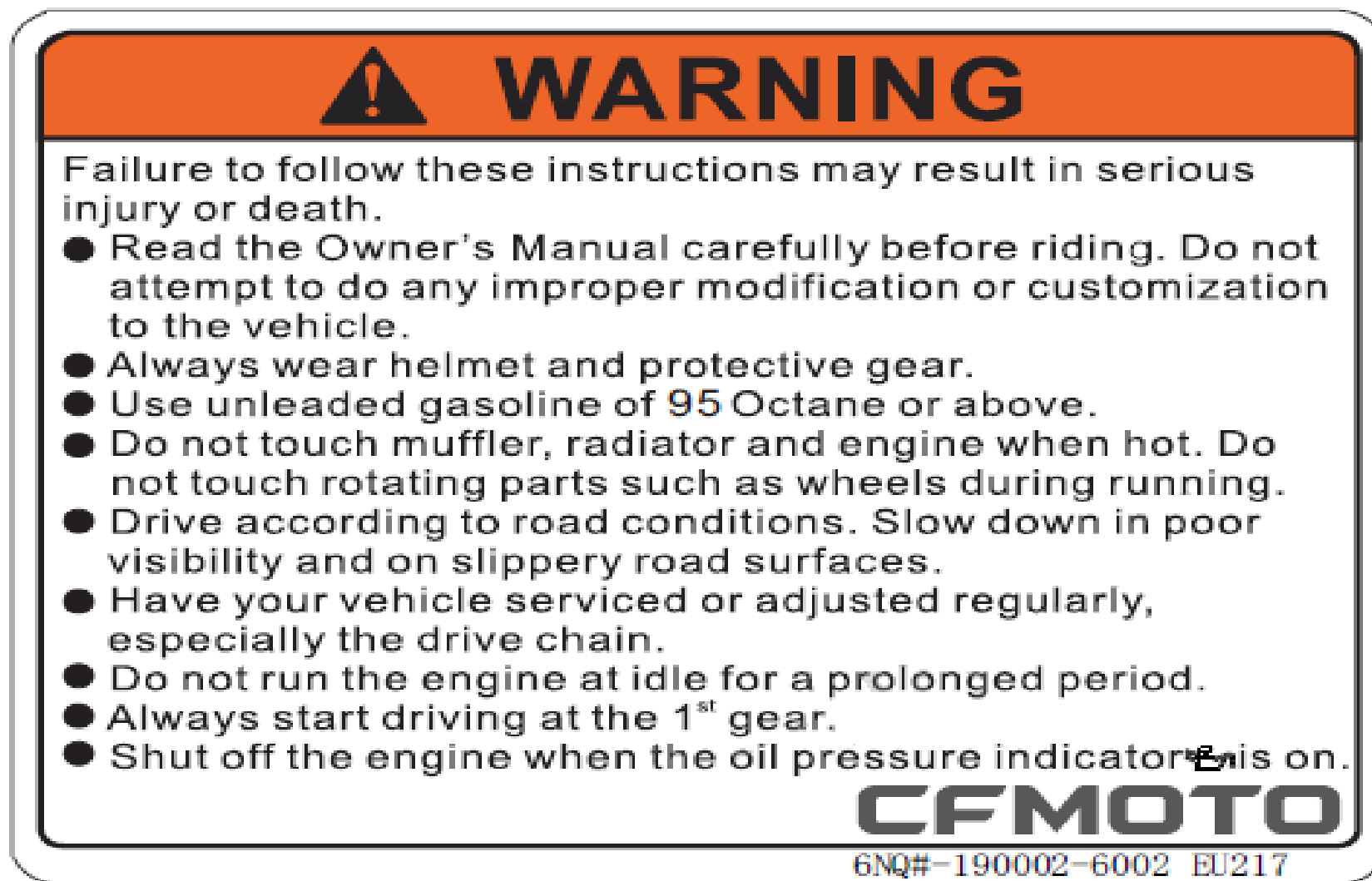

NO.	CODE	EN DESCRIPTION	QTY	REMARKS
F19-1-01	6NQ#-190002-6002	SAFETY WARNING INSTRUCTION LABEL	1	ALT:- A000-190102

F19-2 油箱标牌 L FUEL TANK LABEL

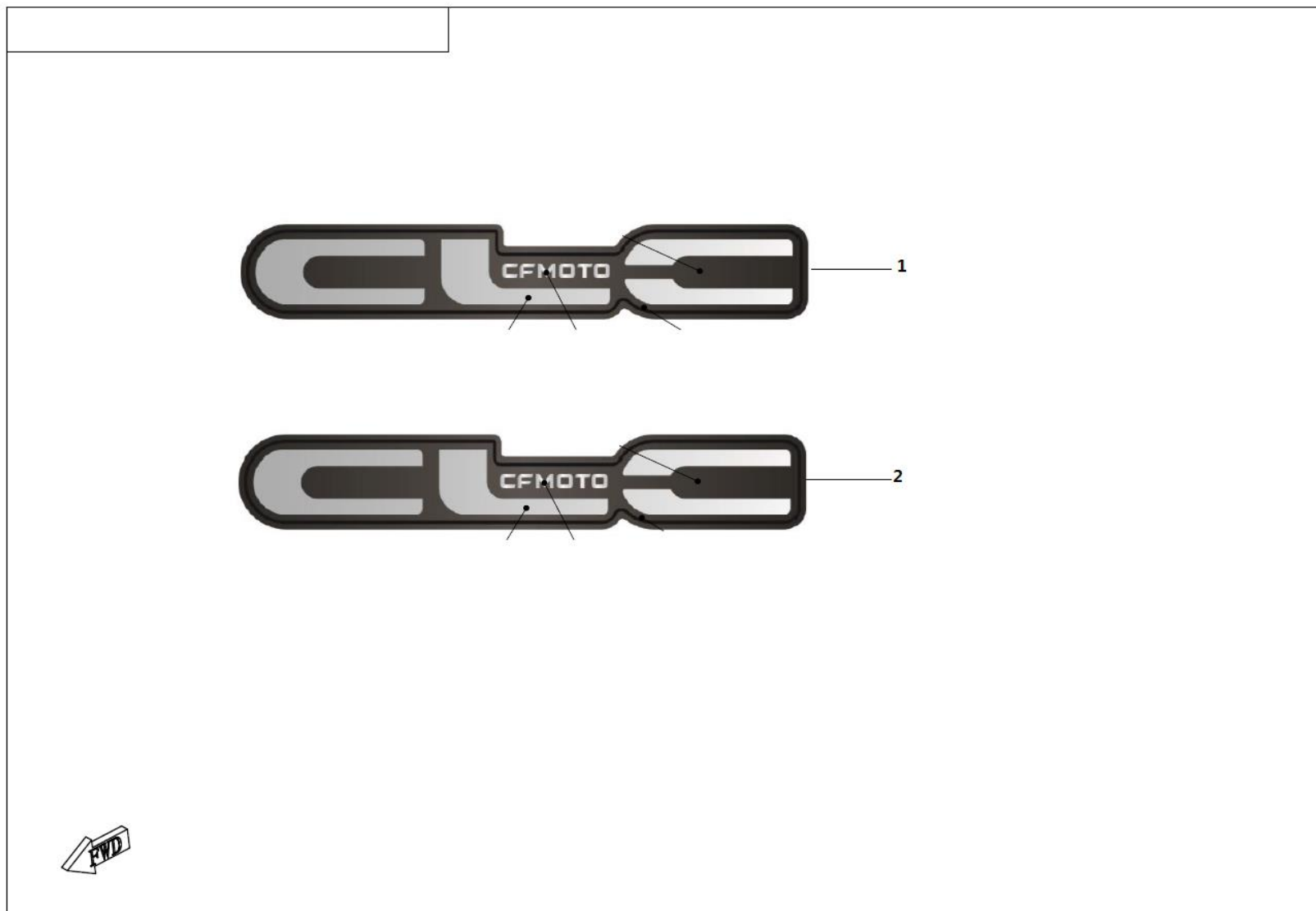

NO.	CODE	EN DESCRIPTION	QTY	REMARKS
F19-2-01	6AQV-190002-7100	LH LABEL, FUEL TANK	1	
F19-2-02	6AQV-190003-7100	RH LABEL, FUEL TANK	1	

工件：左、右护板，外贴

颜色：星光黑

材质：ABS

刀模线尺寸44×8

整模线尺寸46×10



NO.	CODE	EN DESCRIPTION	QTY	REMARKS
F19-3-01	6AQV-190006-7100-10	MODEL DECAL	2	

F20 随车工具 TOOLS

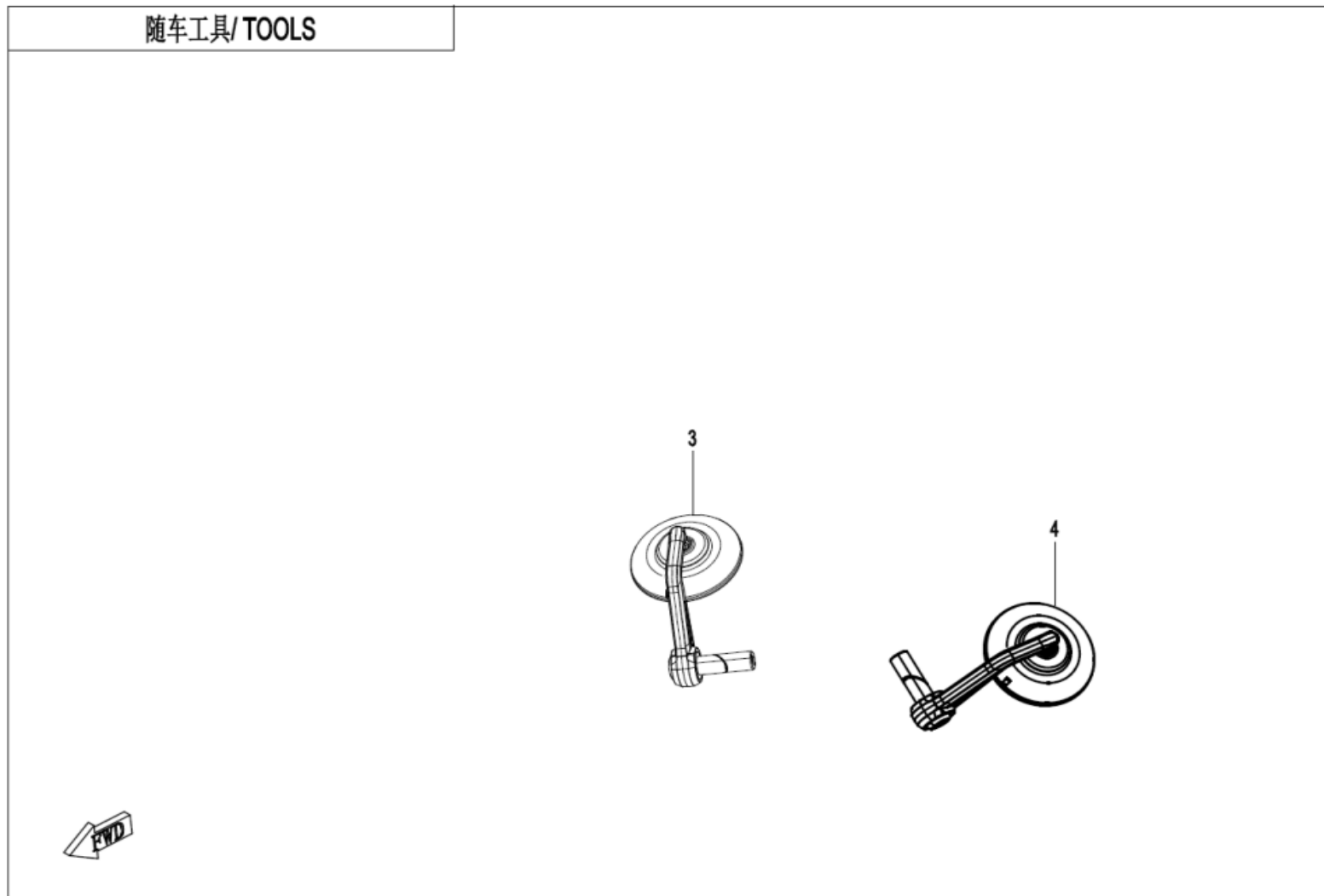

NO.	CODE	EN DESCRIPTION	QTY	REMARKS
F20-03	6AQV-200400-7100	RH REARVIEW ASSY	1	
F20-04	6AQV-200300-7100	LH REARVIEW MIRROR ASSY	1	

燃油蒸发系统/FUEL EVAPORATION SYSTEM

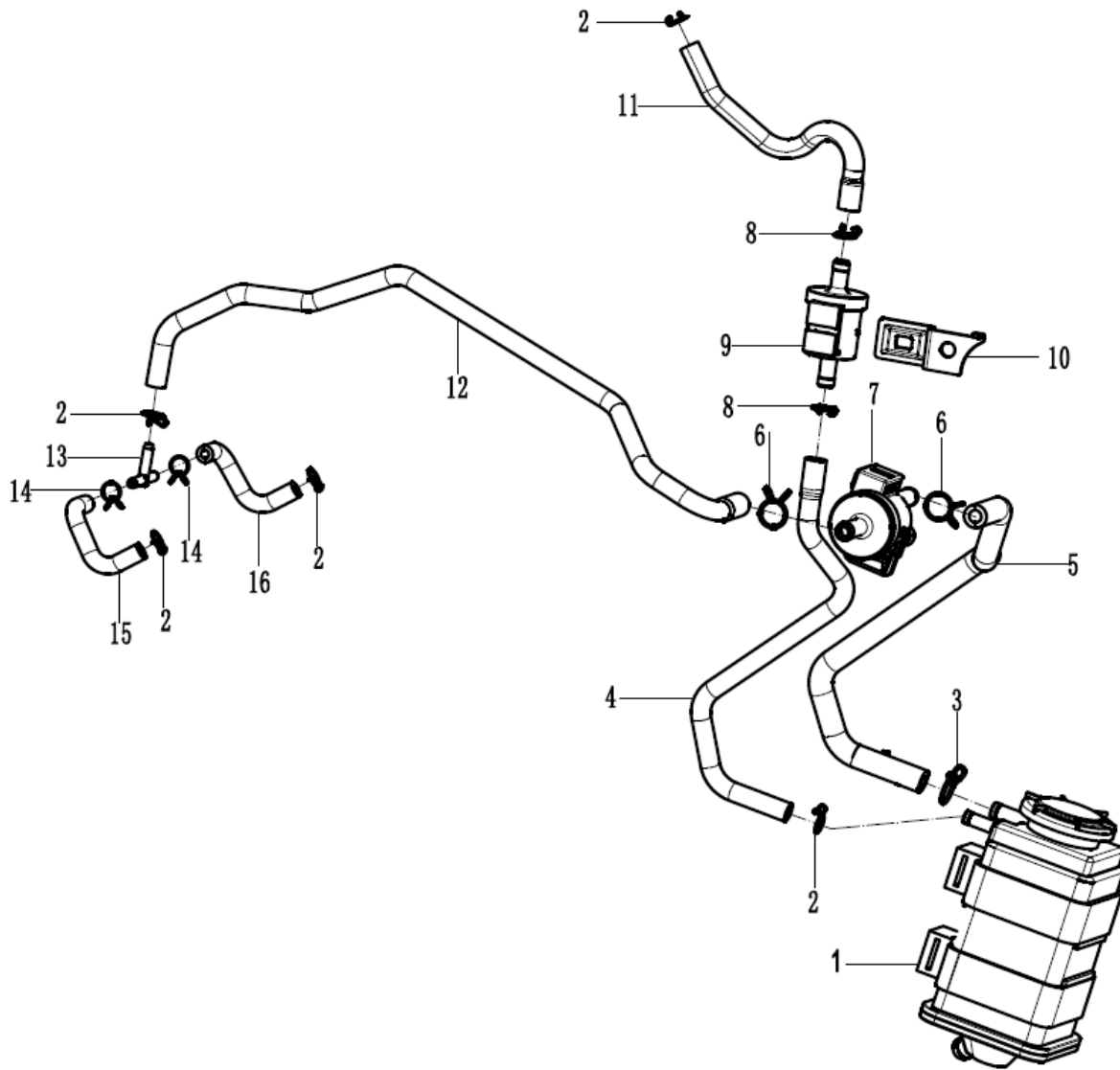

NO.	CODE	EN DESCRIPTION	QTY	REMARKS
F36-01	6L30-360200	CANISTER	1	
F36-02	30601-109010	CLAMP A9	5	
F36-03	30601-111010	CLAMP A11	1	
F36-04	6AQV-360002-7100	FUEL VAPOR ADSORPTION HOSE 2	1	
F36-05	6AQV-360003-7100	FUEL VAPOR DESORPTION HOSE 1	1	
F36-06	30601-112010	CLAMP A12	2	
F36-07	1F30-172000	CANISTER MAGNETIC VALVE	1	
F36-08	30601-110010	CLAMP A10	2	
F36-09	6WWV-360010-5000	"TWO-WAY VALVE	1	
F36-10	6AQV-360005-7100	TWO-WAY VALVE BRACKET	1	
F36-11	6AQV-360001-7100	FUEL VAPOR ADSORPTION HOSE 1	1	
F36-12	6AQV-360004-7100	FUEL VAPOR DESORPTION HOSE 2	1	
F36-13	8010-360001	VACUUM T-JOINT	1	
F36-14	30601-108010	CLAMP A8	2	
F36-15	6AQV-360007-1000	LH FUEL VAPOR DESORPTION HOSE	1	
F36-16	6AQV-360008-1000	RH FUEL VAPOR DESORPTION HOSE	1	

空滤器组/AIR FILTER ASSY

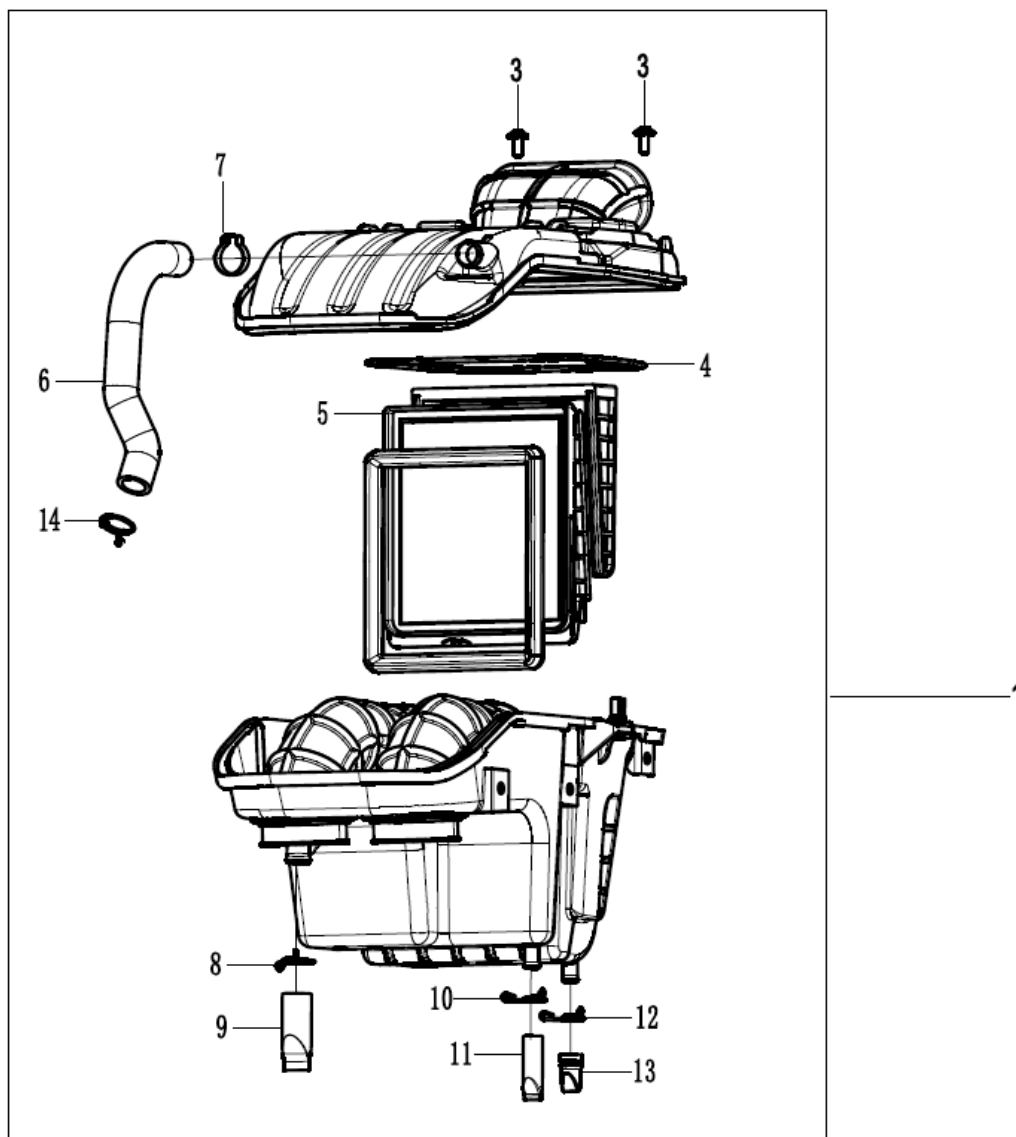

NO.	CODE	EN DESCRIPTION	QTY	REMARKS
F41-01	0SQV-110000-5002	AIR FILTER ASSY	1	
F41-02	0120-110003	CLAMP 52	2	
F41-03	6NTA-040202	INNER HEX SCREW M5x12	2	
F41-04	0SQV-110000-5000-21	SEAL RING	1	
F41-05	0SQV-112000-1000	FILTER ELEMENT	1	
F41-06	0SQV-110005-5000	BREATHER HOSE, CRANKCASE	1	
F41-07	0SQV-110000-5000-24	CLAMP	1	
F41-08	30601-117010	CLAMP A17	1	
F41-09	0SQV-110000-1000-24	STORAGE HOSE	1	
F41-10	30601-110010	CLAMP A10	1	
F41-11	0SQV-110000-1000-25	OIL STORAGE HOSE	1	
F41-12	0SQV-110000-5000-22	CLAMP	1	
F41-13	0SQV-110000-1000-21	VALVE	1	
F41-14	0SQV-110000-5000-20	CLAMP	1	

上曲轴箱分总成和下曲轴箱分总成/UPPER & LOWER CRANKCASE

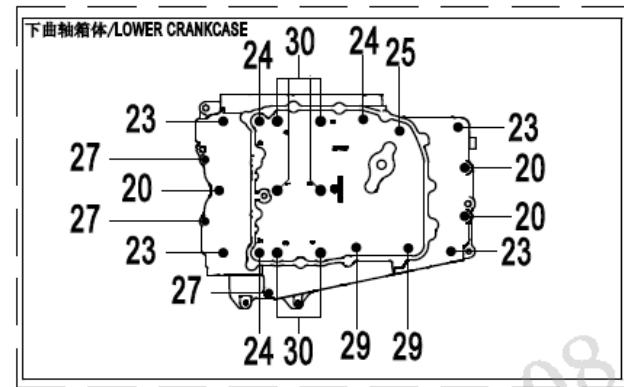
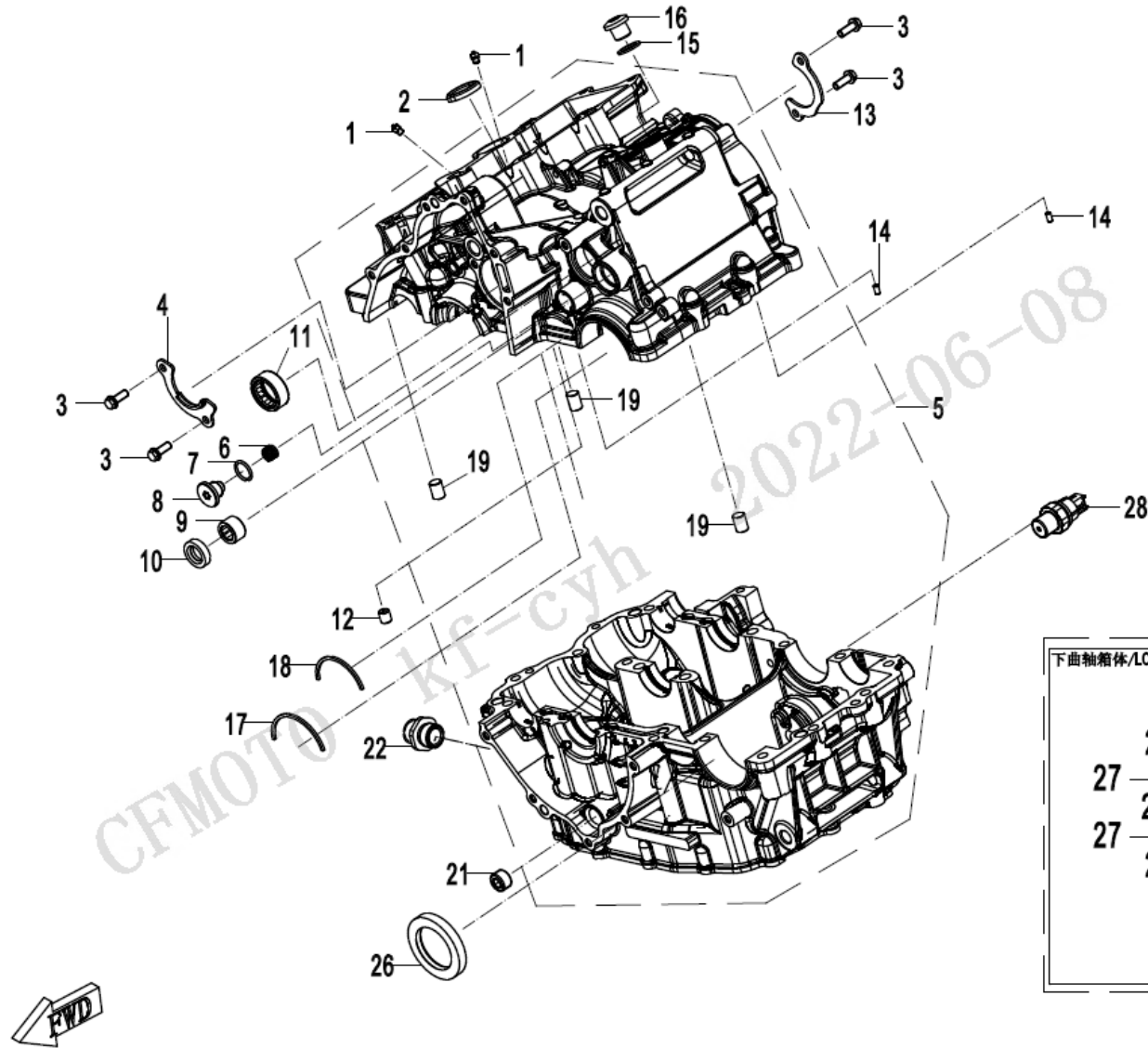

NO.	CODE	EN DESCRIPTION	QTY	REMARKS
E01-1-01	OSQV-011102-1000	OIL NOZZLE Dia.7	2	
E01-1-02	OSQV-011104-1000	SEAL RING, FILLER	1	
E01-1-03	0010-090005-0010	BOLT M6x16	4	
E01-1-04	OSQV-011105-1000	BEARING GUARD, LH	1	
E01-1-05	OSQV-01FZ01-1003-OBP00	CRANKCASE ASSY	1	
E01-1-06	OSQV-060011-1000	BEARING SLEEVE	2	
E01-1-07	OSQV-011107-1000	O-RING 15X1.9	1	
E01-1-08	OSQV-011108-1000	FORK SHAFT COVER	1	
E01-1-09	30403-01400	NEEDLE BEARING	1	
E01-1-10	1F30-011600	OIL SEAL 14X24X6	1	
E01-1-11	30403-02500	BEARING	1	
E01-1-12	OSQV-011103-1000	RESTRICTION PLUG	1	
E01-1-13	OSQV-011106-1000	BEARING GUARD, RH	1	
E01-1-14	30406-00401	ROLLER NEEDLE P4x7.8	2	
E01-1-15	0180-011006	GASKET 14	1	
E01-1-16	0180-021008-00001	BOLT M14X1.25X12	1	
E01-1-17	OSQV-011004-1000	RETAINER, BEARING	1	
E01-1-18	OSQV-011003-1000	RETAINER, BEARING	1	
E01-1-19	30410-01000	ROLLER 10x14	3	
E01-1-20	OSQV-012003-1000	BOLT M8x45	3	
E01-1-21	0700-012105-00001	PLUG, MAIN OIL RAIL	1	
E01-1-22	0700-012106-00002	OIL FILTER BOLT	1	
E01-1-23	OSQV-012002-1000	BOLT M8x65	4	
E01-1-24	OSQV-012500-1000	BOLT ASSY M8X105	3	
E01-1-25	OSQV-012600-1000	BOLT ASSY M8X55	1	
E01-1-26	OSQV-010001-1001	COUNTERSHAFT OIL SEAL 40X58X8	1	
E01-1-27	0010-060012-0010	BOLT M6x30	3	
E01-1-28	OSQV-012400-1000	OIL PRESSURE SWITCH	1	
E01-1-29	OSQV-012700-1000	BOLT ASSY M8X45	2	
E01-1-30	OSQV-012200-1000	BOLT ASSY M9X108	6	

右&左侧盖分总成/RIGHT&LEFT SIDE COVER

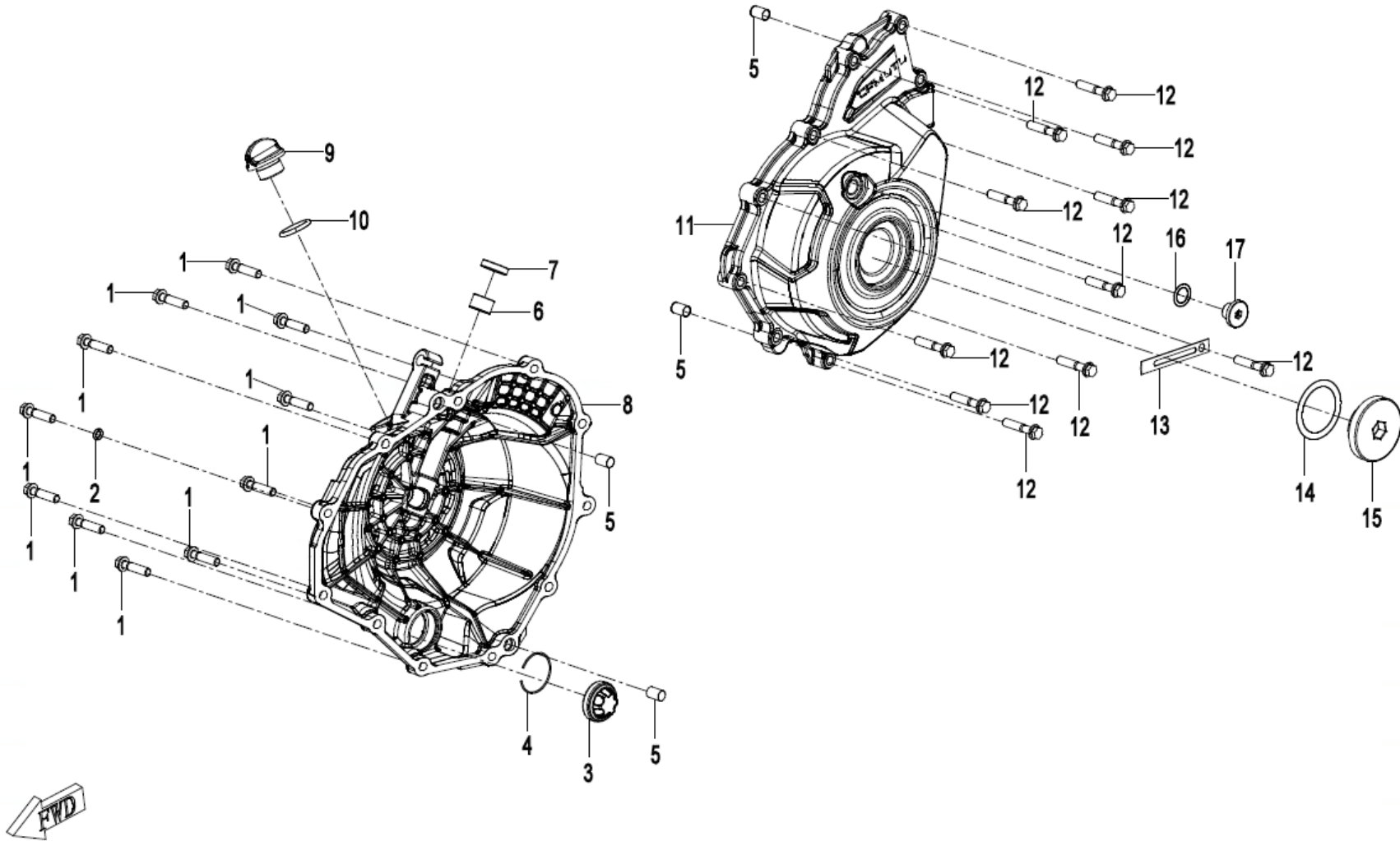

NO.	CODE	EN DESCRIPTION	QTY	REMARKS
E01-2-01	0010-021017-0010	BOLT M6x25	11	
E01-2-02	0700-012201	O-RING 5X2	1	
E01-2-03	OSQV-013100-1000-M1	VIEWER, OIL LEVEL	1	
E01-2-04	OSQV-013001-1000	CIRCLIP	1	
E01-2-05	30410-00800	ROLLER	4	
E01-2-06	30403-01200	BEARING 12X16X10	1	
E01-2-07	0010-080009	OIL SEAL 12X20X5	1	
E01-2-08	OSQV-013010-5000-0D600	RH SIDE COVER (BLACK)	1	
E01-2-09	0700-013008	PLUG, OIL FILLING	1	
E01-2-10	0110-013030	O-RING 18X3.55	1	
E01-2-11	OSQV-014010-5000-0D600	LH SIDE COVER (BLACK)	1	
E01-2-12	0010-060012-0010	BOLT M6x30	11	
E01-2-13	0180-014010	WIRE CLIP	1	
E01-2-14	01A0-012003	O-RING 35X3.5	1	
E01-2-15	01A0-012002-0D600	COVER, OIL STRAINER (BLACK)	1	
E01-2-16	ODM0-011006	O-RING 13X2	1	
E01-2-17	ODM0-014003	VIEWING HOLE, TIMING INSPECTION	1	

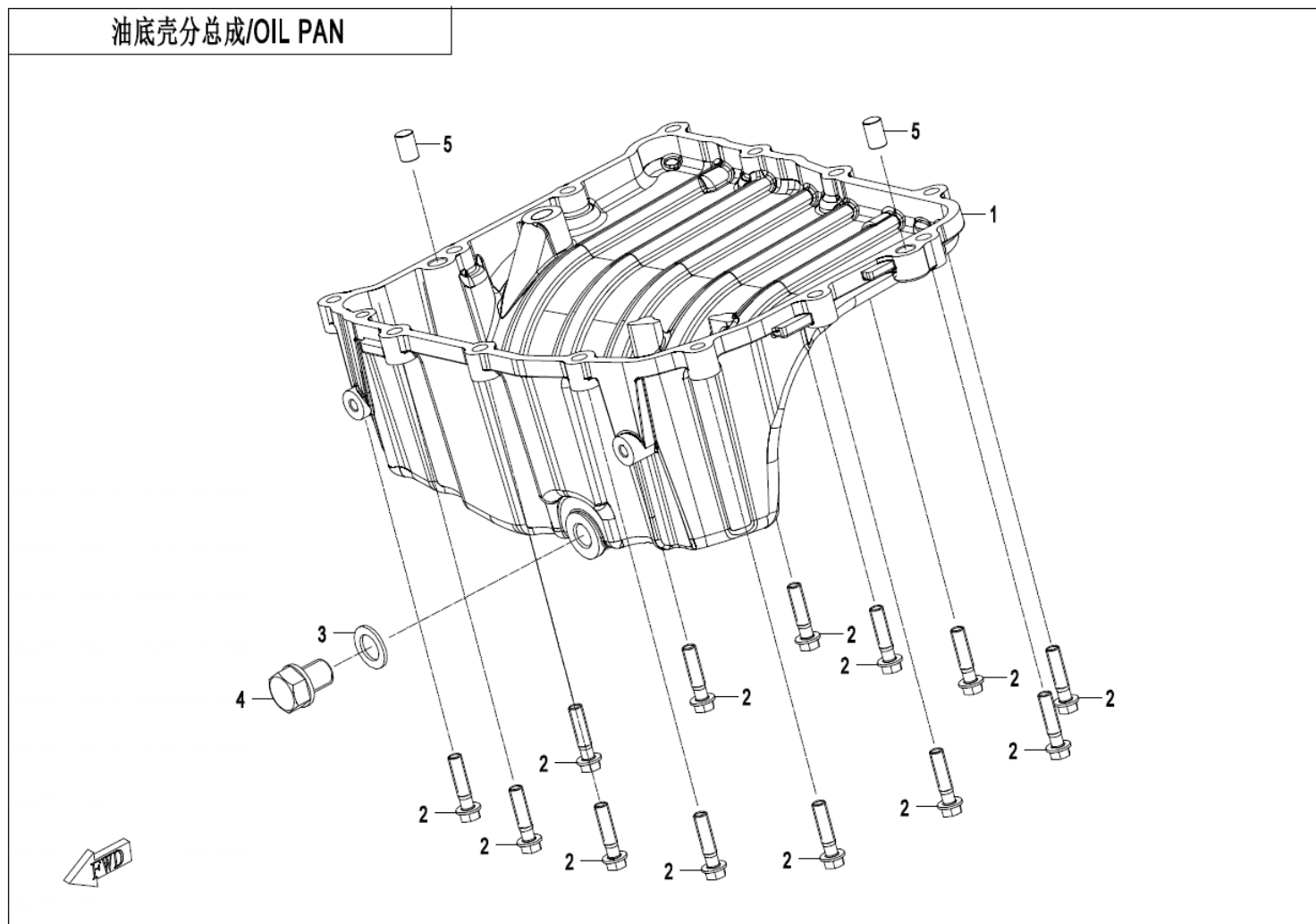

NO.	CODE	EN DESCRIPTION	QTY	REMARKS
E01-3-01	OSQV-015001-1001-0BP00	OIL PAN	1	
E01-3-02	0010-021017-0010	BOLT M6x25	13	
E01-3-03	0010-021014	WASHER 12	1	
E01-3-04	0180-011500	MAGNETIC DRAIN BOLT	1	
E01-3-05	30410-00800	ROLLER	2	

气缸盖罩分总成/CYLINDER HEAD COVER

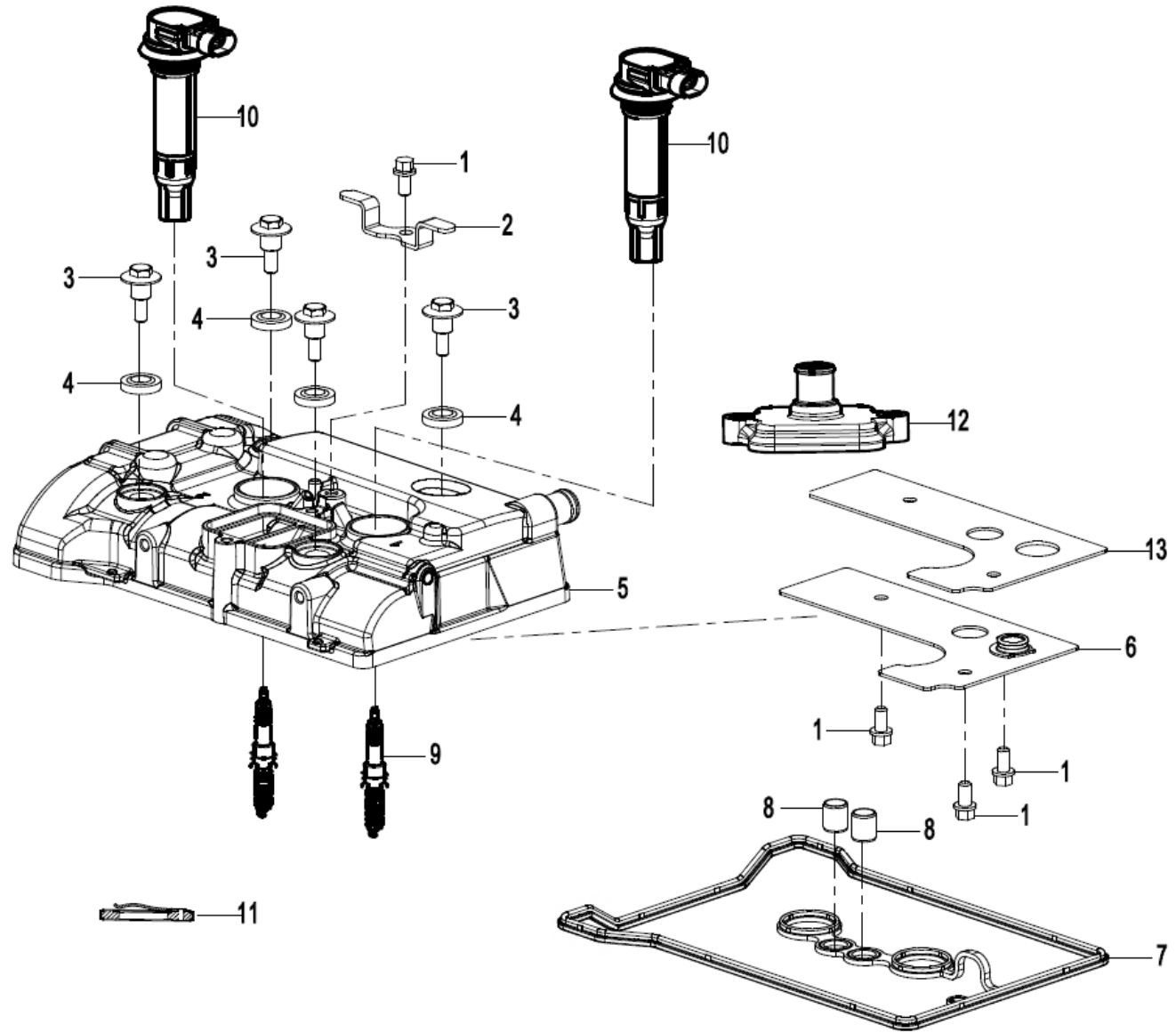

NO.	CODE	EN DESCRIPTION	QTY	REMARKS
E02-1-01	0010-021019-0010	BOLT M6x12	4	
E02-1-02	0SQV-021004-1000	PRESS PLATE	1	
E02-1-03	0700-021003-00001	CYLINDER HEAD COVER BOLT (GALVANIZED TRIVALENT CHRO)	4	
E02-1-04	0700-021200	CYLINDER HEAD COVER BOLT SEAL RING	4	
E02-1-05	0SQV-021010-1000-10-0BP00	CYLINDER HEAD COVER	1	
E02-1-05	0SQV-021010-1000-0BP00	CYLINDER HEAD COVER (MAUD SPIRIT BLACK)	1	
E02-1-06	0SQV-021100-1000	PRESS PLATE	1	
E02-1-07	0SQV-021002-1000	GASKET, CYLINDER HEAD COVER	1	
E02-1-08	0HU0-021002	GULP PIN	2	
E02-1-08	0HU0-021002-00001	GULP PIN	2	
E02-1-09	0SQV-170200-1000	SPARK PLUG	2	
E02-1-10	0SQV-178000-1000	IGNITION COIL	2	
E02-1-11	0MQB-021100-20001	SPRING VALVE ASSY	1	
E02-1-12	0SQV-021020-1000-0BP00	CAP, ONE-WAY VALVE (MAUD SPIRIT BLACK)	1	
E02-1-13	0SQV-021005-1000	LABYRINTH COVER GASKET	1	

气缸盖分总成(1)/CYLINDER HEAD(1)

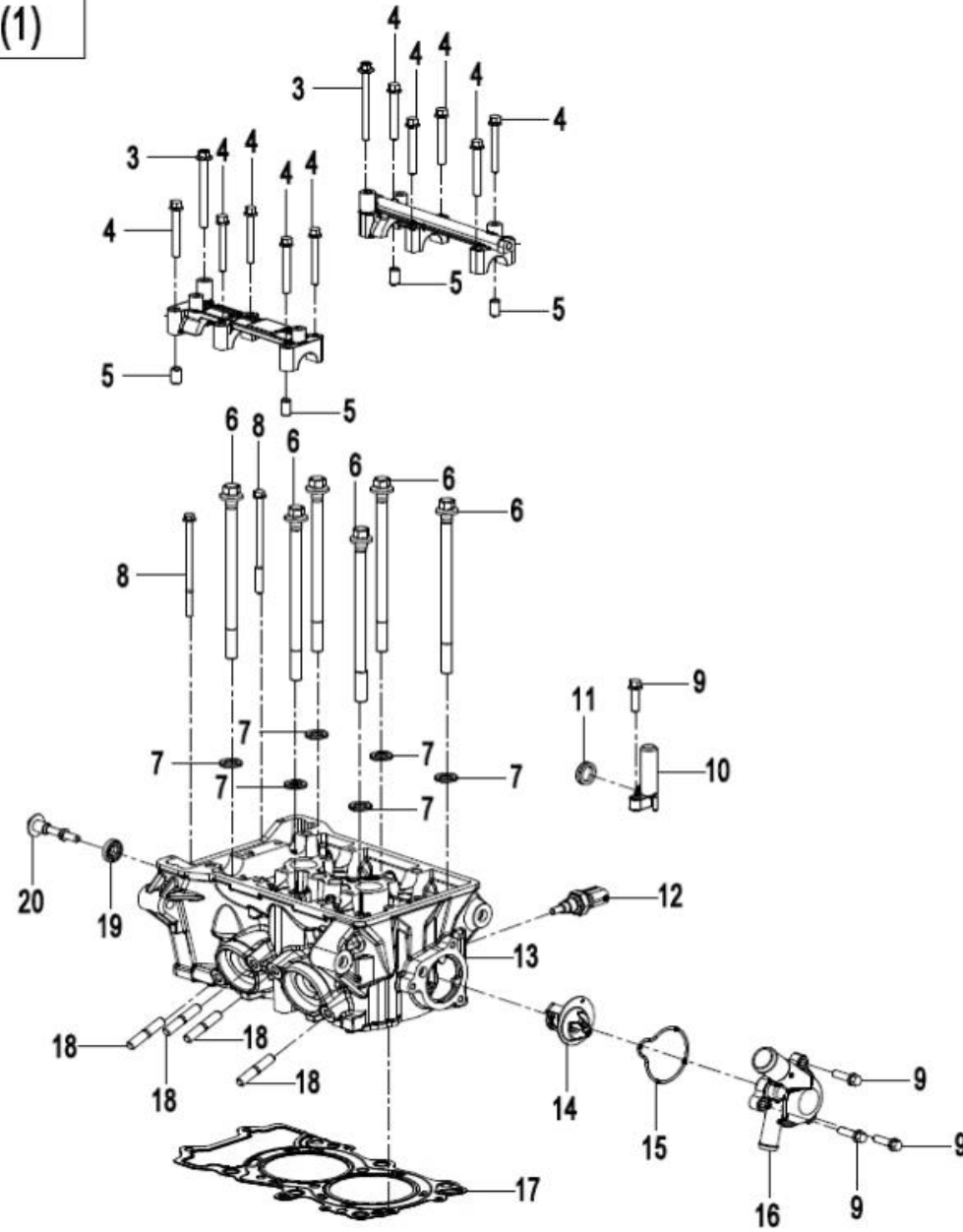

NO.	CODE	EN DESCRIPTION	QTY	REMARKS
E02-2-03	0SQV-022105-1000	BOLT M6x65	2	
E02-2-04	0SQV-022106-1001	HEX FLANGE BOLT	10	
E02-2-05	0DM0-022201-10000	DOWEL PIN 8x12	4	
E02-2-06	0SQV-022008-1000	CYLINDER HEAD BOLT M10X150	6	
E02-2-07	0700-022016	WASHER 10.5x19x2.3	6	
E02-2-08	0SQV-022011-1000	BOLT M6x90	2	
E02-2-09	0010-022020-00002	BOLT M6x22	4	
E02-2-10	0SQV-022200-1000	CONNECTOR ASSY.	1	
E02-2-11	1F30-024016	OIL SEAL, SURFACE	1	
E02-2-12	018B-022810	WATER TEMPERATURE SENSOR	1	
E02-2-14	0MQ0-022500	THERMOSTAT	1	
E02-2-15	0SQV-022002-1000	SEAL RING, THERMOSTAT CAP	1	
E02-2-16	0SQV-022001-1000-10-0BP00	THERMOSTAT CAP (MAUD SPIRIT BLACK)	1	
E02-2-17	0SQV-022300-1000	GASKET, CYLINDER HEAD	1	
E02-2-18	0180-022003-00001	STUD	4	
E02-2-19	0700-021200	CYLINDER HEAD COVER BOLT SEAL RING	1	
E02-2-20	0DM0-022008-00001	CYLINDER HEAD DAMPING BOLT	1	
E02-2-21	0SQV-022100-1003-0BP00	CYLINDER HEAD ASSY	1	

气缸盖分总成(2)/CYLINDER HEAD(2)

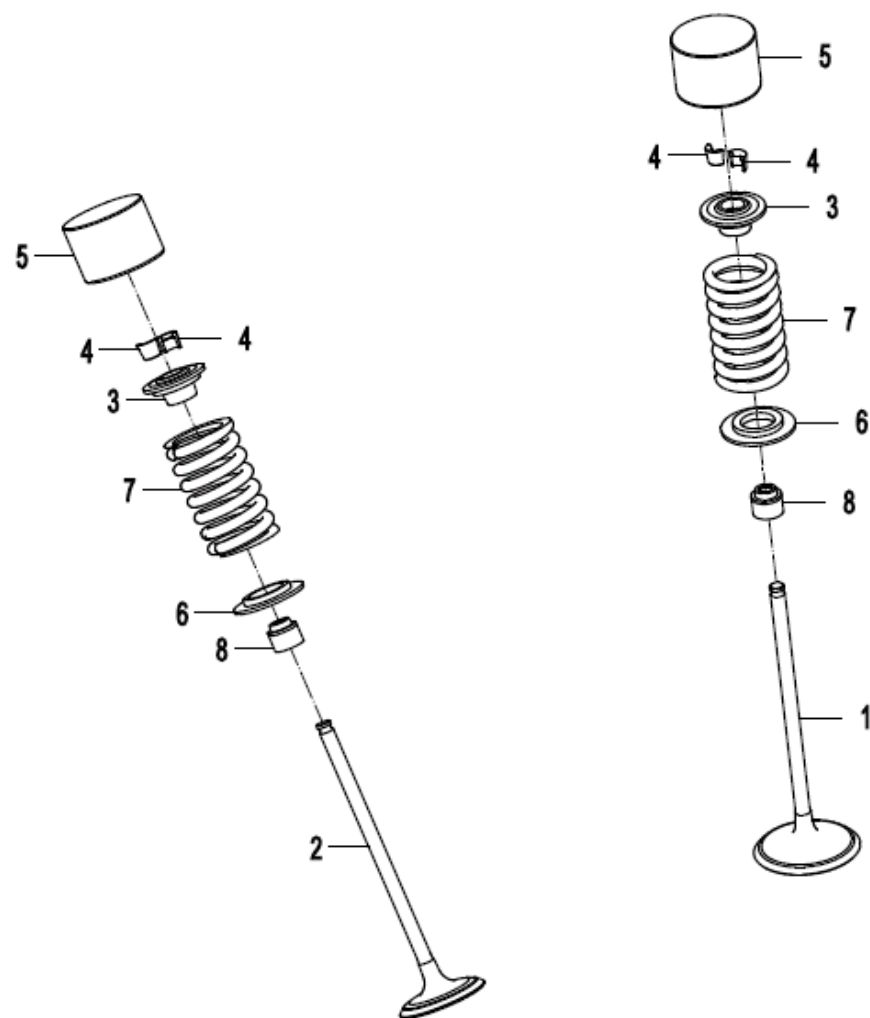

NO.	CODE	EN DESCRIPTION	QTY	REMARKS
E02-3-01	0SQV-022004-1000	VALVE, INTAKE	4	
E02-3-02	0SQV-022005-1000	VALVE, EXHAUST	4	
E02-3-03	0MQ0-022003	UPPER SEAT, VALVE SPRING	8	
E02-3-04	0700-022004	LOCK CLIP, VALVE	16	
E02-3-05	0MQ0-022005-0370	TAPPET T=3.94	8	
E02-3-05	0MQ0-022005-0380	TAPPET T=3.96	8	
E02-3-05	0MQ0-022005-0390	TAPPET T=3.98	8	
E02-3-05	0MQ0-022005-0400	TAPPET T=4.00	8	
E02-3-05	0MQ0-022005-0410	TAPPET T=4.02	8	
E02-3-05	0MQ0-022005-0420	TAPPET T=4.04	8	
E02-3-05	0MQ0-022005-0430	TAPPET T=4.06	8	
E02-3-05	0MQ0-022005-0440	TAPPET T=4.08	8	
E02-3-05	0MQ0-022005-0450	TAPPET T=4.10	8	
E02-3-05	0MQ0-022005-0460	TAPPET T=4.12	8	
E02-3-05	0MQ0-022005-0470	TAPPET T=4.14	8	
E02-3-05	0MQ0-022005-0480	TAPPET T=4.16	8	
E02-3-05	0MQ0-022005-0490	TAPPET T=4.18	8	
E02-3-05	0MQ0-022005-0070	TAPPET T=3.34	8	
E02-3-05	0MQ0-022005-0080	TAPPET T=3.36	8	
E02-3-05	0MQ0-022005-0090	TAPPET T=3.38	8	
E02-3-05	0MQ0-022005-0100	TAPPET T=3.40	8	
E02-3-05	0MQ0-022005-0110	TAPPET T=3.42	8	
E02-3-05	0MQ0-022005-0120	TAPPET T=3.44	8	
E02-3-05	0MQ0-022005-0130	TAPPET T=3.46	8	
E02-3-05	0MQ0-022005-0140	TAPPET T=3.48	8	
E02-3-05	0MQ0-022005-0150	TAPPET T=3.50	8	
E02-3-05	0MQ0-022005-0160	TAPPET T=3.52	8	
E02-3-05	0MQ0-022005-0170	TAPPET T=3.54	8	
E02-3-05	0MQ0-022005-0180	TAPPET T=3.56	8	
E02-3-05	0MQ0-022005-0190	TAPPET T=3.58	8	
E02-3-05	0MQ0-022005-0200	TAPPET T=3.60	8	
E02-3-05	0MQ0-022005-0210	TAPPET T=3.62	8	

NO.	CODE	EN DESCRIPTION	QTY	REMARKS
E02-3-05	0MQ0-022005-0220	TAPPET T=3.64	8	
E02-3-05	0MQ0-022005-0230	TAPPET T=3.66	8	
E02-3-05	0MQ0-022005-0240	TAPPET T=3.68	8	
E02-3-05	0MQ0-022005-0250	TAPPET T=3.70	8	
E02-3-05	0MQ0-022005-0260	TAPPET T=3.72	8	
E02-3-05	0MQ0-022005-0270	TAPPET T=3.74	8	
E02-3-05	0MQ0-022005-0280	TAPPET T=3.76	8	
E02-3-05	0MQ0-022005-0290	TAPPET T=3.78	8	
E02-3-05	0MQ0-022005-0300	TAPPET T=3.80	8	
E02-3-05	0MQ0-022005-0310	TAPPET T=3.82	8	
E02-3-05	0MQ0-022005-0320	TAPPET T=3.84	8	
E02-3-05	0MQ0-022005-0330	TAPPET T=3.86	8	
E02-3-05	0MQ0-022005-0340	TAPPET T=3.88	8	
E02-3-05	0MQ0-022005-0350	TAPPET T=3.90	8	
E02-3-05	0MQ0-022005-0360	TAPPET T=3.92	8	
E02-3-06	0SQV-022006-2000	LOWER SEAT, VALVE SPRING	8	
E02-3-07	0SQV-022003-1000-10	VALVE SPRING	8	
E02-3-08	0700-022400-1000	SEAL RING, VALVE STEM	8	

E02-4 气缸盖分总成(3) CYLINDER HEAD(3)

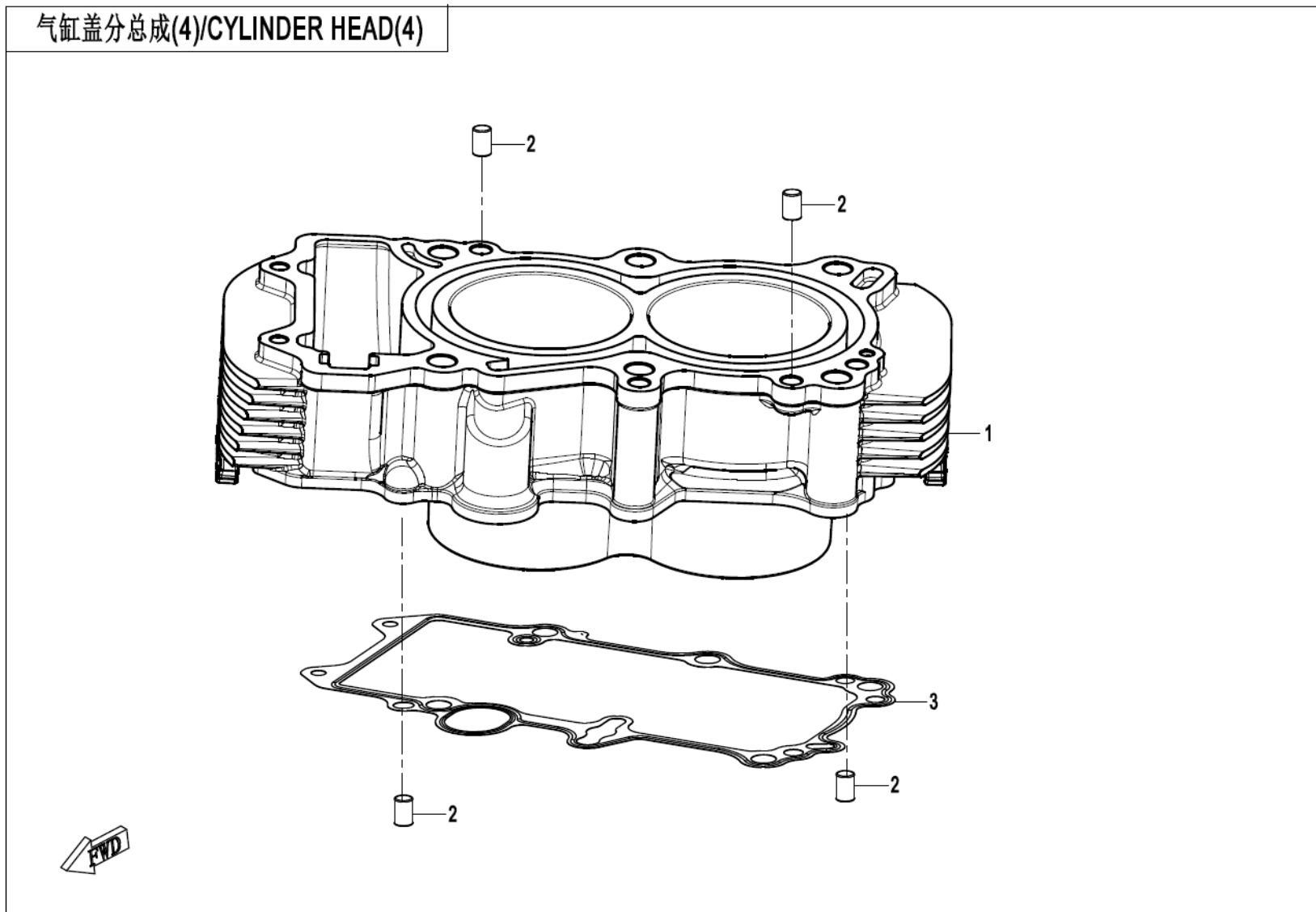

NO.	CODE	EN DESCRIPTION	QTY	REMARKS
E02-4-01	OSQV-023010-5000-0BP00	CYLINDER BODY ASSY (MAUD SPIRIT BLACK)	1	
E02-4-02	30410-00800	ROLLER	4	
E02-4-03	OSQV-023002-1000	GASKET, CYLINDER	1	

配气传动分总成/CAMSHAFT

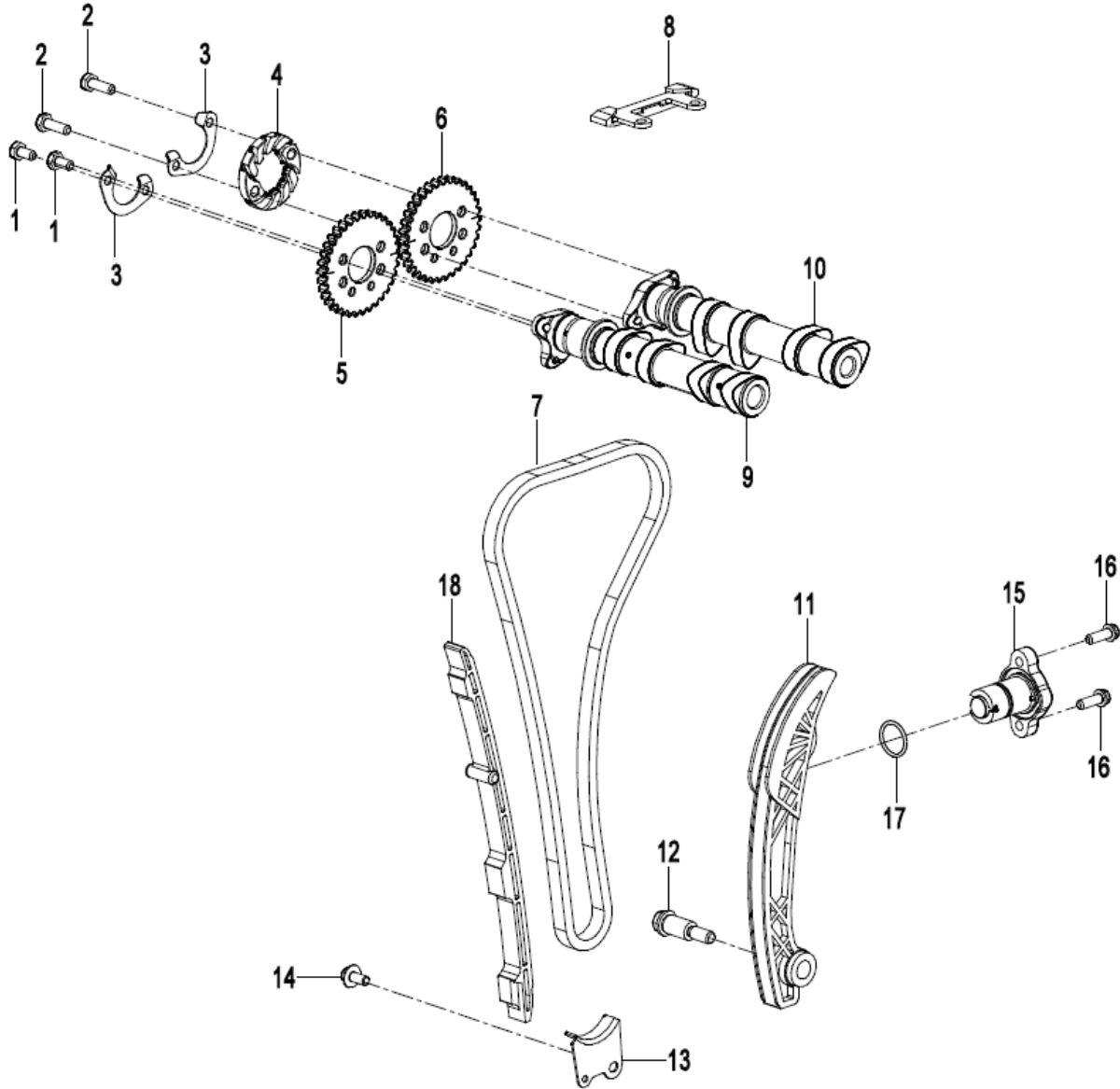

NO.	CODE	EN DESCRIPTION	QTY	REMARKS
E02-5-01	30004-060012150	BOLT	2	
E02-5-02	1F30-024012	BOLT M6x18	2	
E02-5-03	0700-024003	RETAINER	2	
E02-5-04	0SQV-024013-1001	CENTRIFUGAL WHEEL	1	
E02-5-05	0SQV-024002-1000	AIR OUTLET TIMING SPROCKET	1	
E02-5-06	0SQV-024001-1000	AIR INLET TIMING SPROCKET	1	
E02-5-07	0SQV-024200-1000	TIMING CHAIN	1	
E02-5-08	0SQV-024100-1000	CHAIN GUIDE BLOCK	1	
E02-5-09	0SQV-024600-2000	CAMSHAFT,EXHAUST	1	
E02-5-10	0SQV-024500-2000	CAMSHAFT,INLET	1	
E02-5-11	0SQV-024005-1001	TENSION PLATE	1	
E02-5-12	0SQV-024009-1000	PIN SHAFT	1	
E02-5-13	0SQV-024008-1000	PLATE, TIMING CHAIN	1	
E02-5-14	0010-021019-0010	BOLT M6x12	1	
E02-5-15	0SQV-024400-1001	HYDRAULIC TENSIONOR	1	
E02-5-16	0010-023010-0010	BOLT M6x20	2	
E02-5-17	0SQV-024401-1000	GASKET, HYDRAULIC TENSIONER	1	
E02-5-18	0SQV-024003-1001	CHAIN GUARD	1	

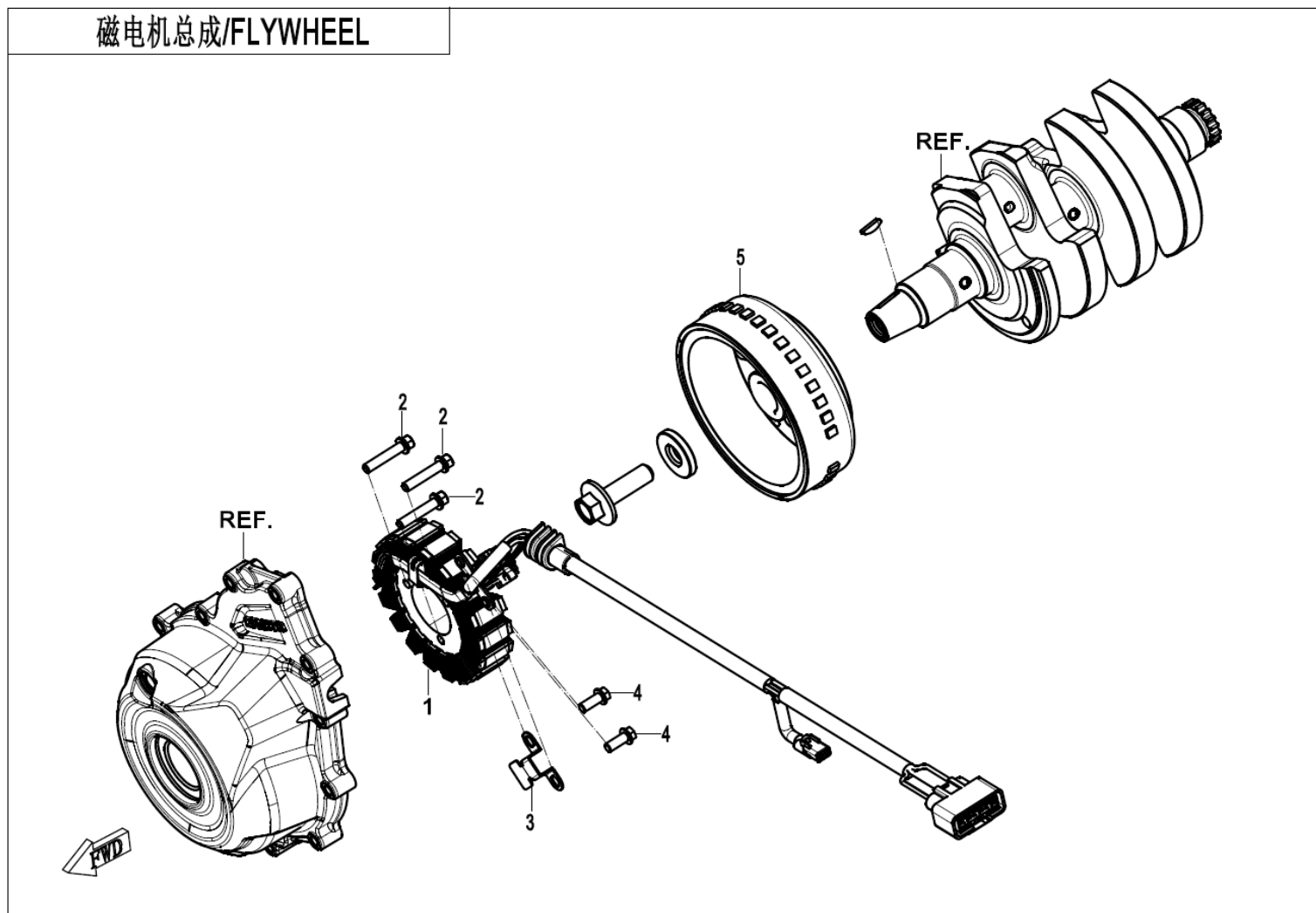

NO.	CODE	EN DESCRIPTION	QTY	REMARKS
E03-01	0SQV-032000-5000	MAGNETO STATOR ASSY	1	
E03-02	0010-021017-0010	BOLT M6x25	3	
E03-03	0SQV-032100-1000	STATER WIRE PRESS PLATE	1	
E03-04	0010-030002-00001	BOLT	2	
E03-05	0SQV-031000-1000-M1	MAGNETO ROTOR	1	

曲轴连杆总成(1)/CRANKSHAFT &CONNECTING ROD(1)

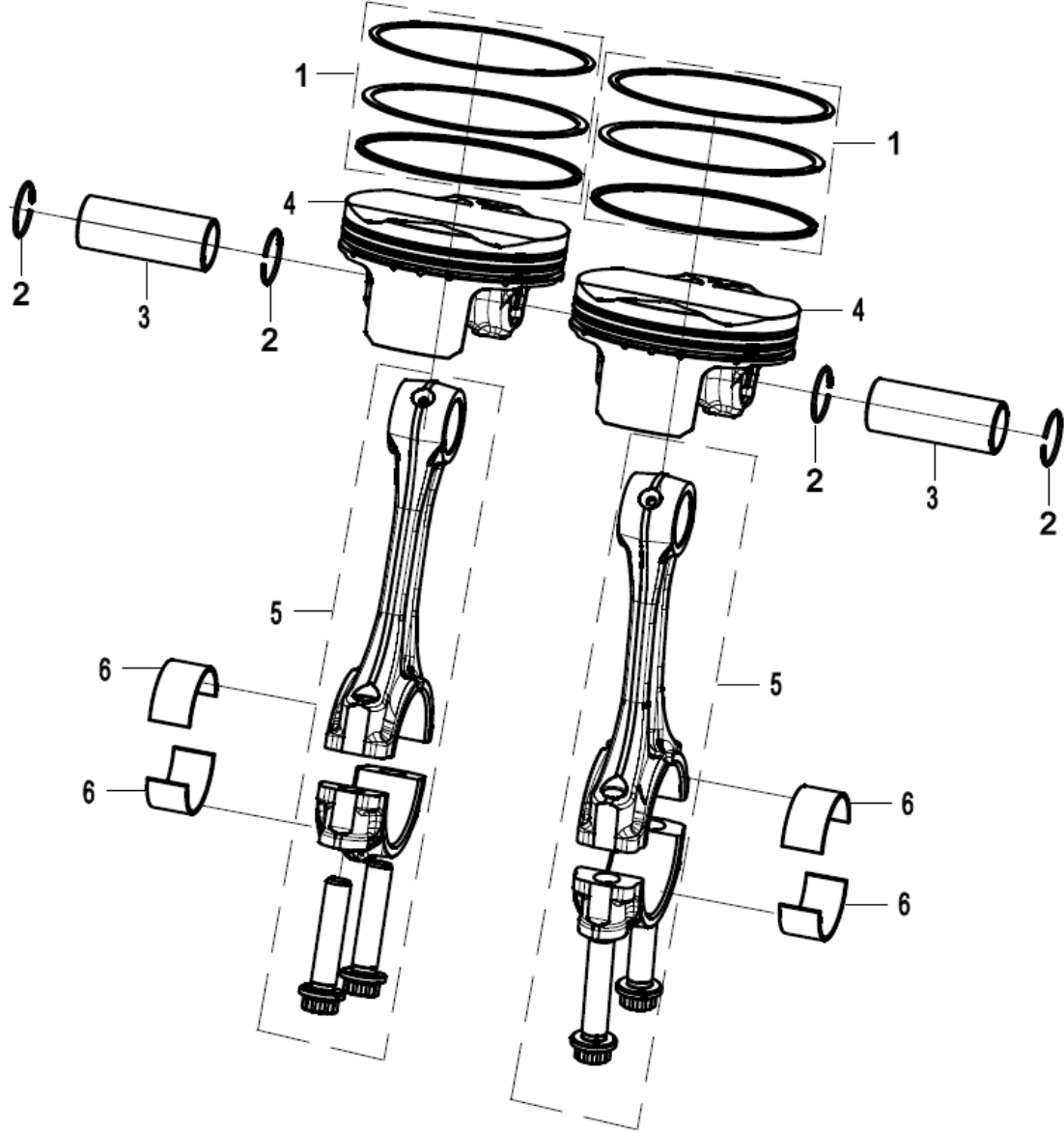

NO.	CODE	EN DESCRIPTION	QTY	REMARKS
E04-1-01	0SQV-040110-10A0	PISTON RING KIT	2	
E04-1-02	0110-040006-0050	CIRCLIP, PISTON PIN	4	
E04-1-03	0SQV-040008-1000	PISTON PIN	2	
E04-1-04	0SQV-040007-1001-Q0-00001	PISTON (MARK I)	2	
E04-1-04	0SQV-040007-1001-Q0-00002	PISTON	2	
E04-1-05	0SQV-042000-1001-Q0-00001	CONNECTING ROD ASSY	2	
E04-1-06	0SQV-042000-1001-Q0-00002	CONNECTING ROD ASSY	2	
E04-1-06	0SQV-040009-1000-Q0-00001	PLAIN BEARING, CONNECTING ROD (RED)	4	
E04-1-06	0SQV-040009-1000-Q0-00002	PLAIN BEARING, CONNECTING ROD (BLACK)	4	
E04-1-06	0SQV-040009-1000-Q0-00003	PLAIN BEARING, CONNECTING ROD (BLUE)	4	

曲轴连杆总成(2)/CRANKSHAFT &CONNECTING ROD(2)

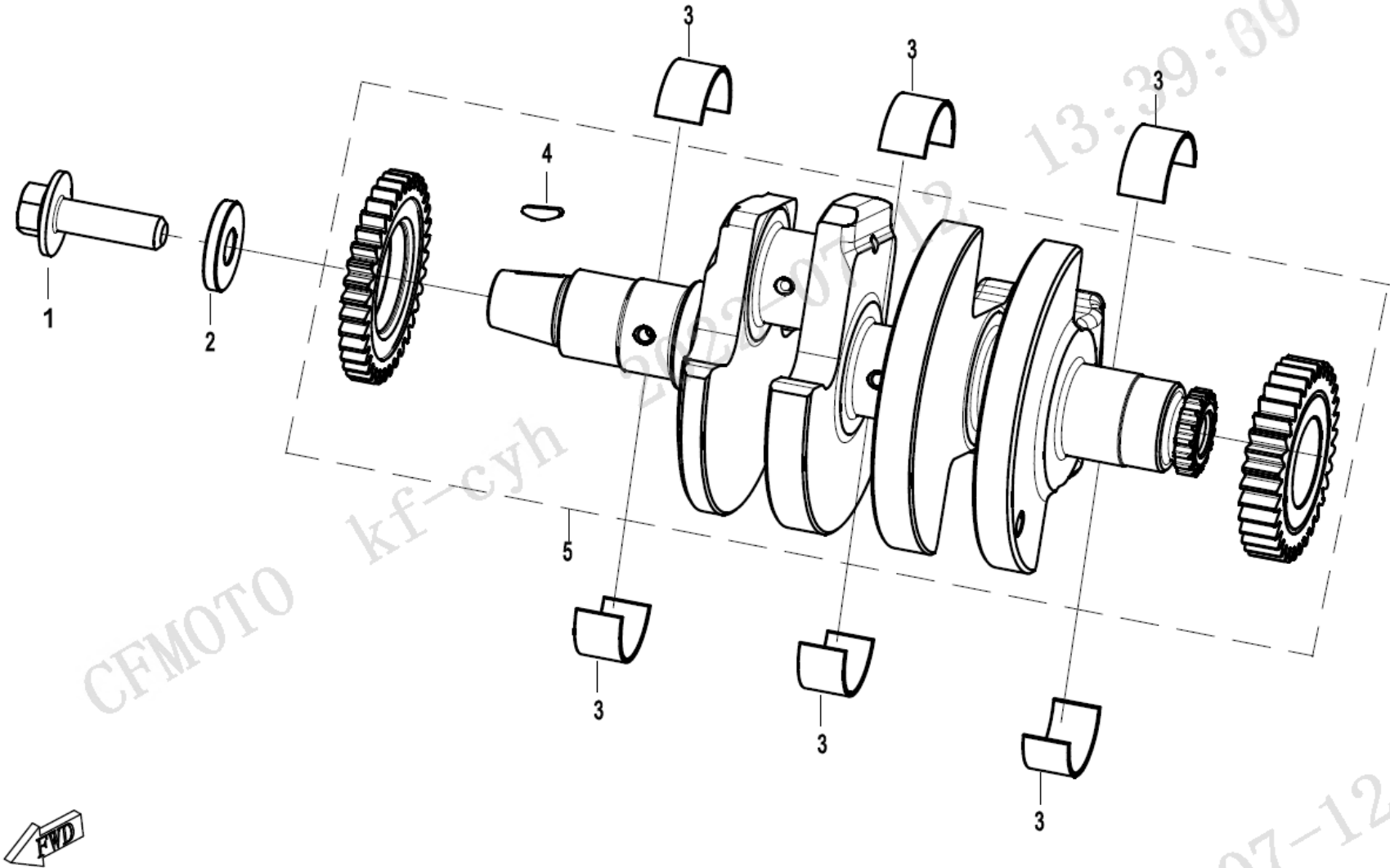

NO.	CODE	EN DESCRIPTION	QTY	REMARKS
E04-2-01	0SQV-040001-1000	BOLT M12x1.25x40	1	
E04-2-02	0700-040002-00001	WASHER	1	
E04-2-03	0SQV-011001-1000-Q0-00001	PLAIN BEARING, MAIN SHAFT	6	
E04-2-03	0SQV-011001-1000-Q0-00002	PLAIN BEARING, MAIN	6	
E04-2-03	0SQV-011001-1000-Q0-00003	PLAIN BEARING, MAIN SHAFT	6	
E04-2-04	0180-040007	WOODRUFF KEY	1	
E04-2-05	0SQV-041000-1000-Q0-00001	CRANKSHAFT ASSY	1	
E04-2-05	0SQV-041000-1000-Q0-00002	CRANKSHAFT ASSY	1	

离合器总成/CLUTCH ASSY

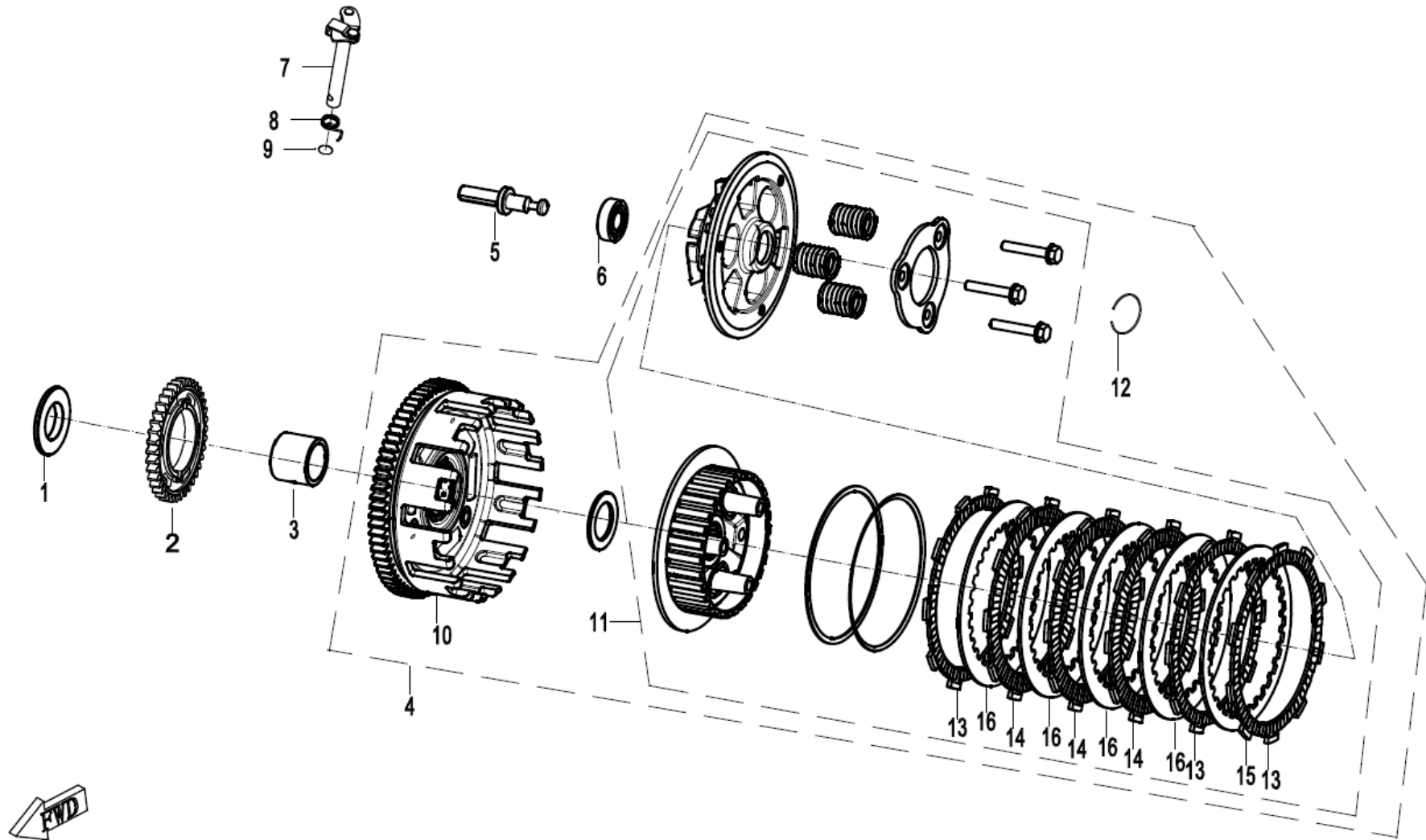

NO.	CODE	EN DESCRIPTION	QTY	REMARKS
E05-01	0SQV-050001-1000	WASHER 25.2X46X5.8	1	
E05-02	0SQV-050005-1001	DRIVE GEAR, OIL PUMP	1	
E05-02	0SQV-050005-1000-10	DRIVE GEAR, OIL PUMP	1	
E05-03	0SQV-050002-1000	AXLE SLEEVE, CLUTCH	1	
E05-04	0SQV-051000-1000-Q1-00001	CLUTCH SUB ASSY (MARK A)	1	
E05-04	0SQV-051000-1000-Q1-00002	CLUTCH SUB ASSY (MARK B)	1	
E05-05	0SQV-050004-1001	ROD	1	
E05-06	30400-01207	ROLLER BEARING	1	
E05-07	0SQV-050100-1000	CLUTCH CONTROL SHAFT ASSY	1	
E05-08	0700-013006-10000	RETURN SPRING, CLUTCH CONTROL LEVER	1	
E05-09	0700-013007	WASHER 12.5X18.5X0.6	1	
E05-10	0SQV-051100-1002	PRIMARY DRIVEN PULLEY ASSY	1	
E05-11	0SQV-051200-1000-M1	CENTRAL SLEEVE ASSY	1	
E05-12	0SQV-060004-1000	LOCK WASHER	1	
E05-13	0SQV-051210-1000-M1	FRICTION DISC ASSY 1	3	
E05-14	0SQV-051220-1000-M1	FRICTION DISC ASSY 2	3	
E05-15	0SQV-051213-1000-M1	DRIVEN DISC 1	1	
E05-16	0SQV-051214-1000-M1	DRIVEN DISC 2	1	

换档变速总成(1)/TRANSMISSION SYSTEM(1)

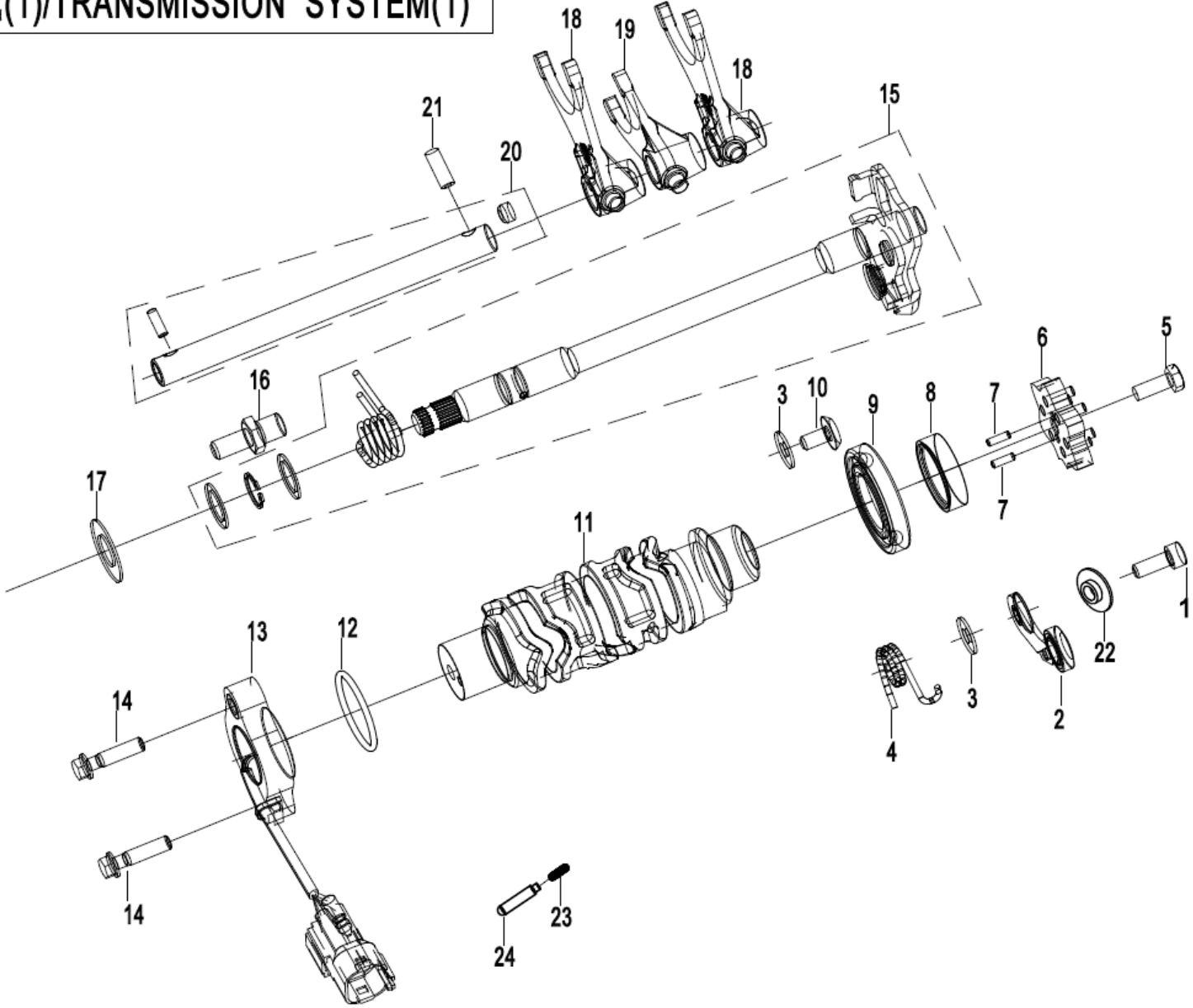

NO.	CODE	EN DESCRIPTION	QTY	REMARKS
E06-1-01	30102-060016810	SCREW M6X16	1	
E06-1-02	0SQV-065100-1000	SPRING, ROCKER ARM	1	
E06-1-03	0700-064001	WASHER 6.3X16.3X1.2	2	
E06-1-04	0DM0-065001	SPRING, SWING ARM, GEARSHIFT	1	
E06-1-05	30004-060016110	BOLT M6x16	1	ALT:- 30004-060016130
E06-1-06	0SQV-064100-1002	CAM, GEARSHIFT DRUM	1	
E06-1-07	30406-00303	NEEDLE BEARING	2	
E06-1-08	0SQV-064002-1000	SHIFT DRUM BUSHING	1	
E06-1-09	30400-02505	BEARING	1	
E06-1-10	0010-090005-0010	BOLT M6x16	1	
E06-1-11	0SQV-064001-1001	SHIFT DRUM	1	
E06-1-12	0SQV-060012-1000	O-RING 31X2.5	1	
E06-1-13	0SQV-060400-1000	GEAR SENSOR	1	
E06-1-14	0010-021017-0010	BOLT M6x25	2	
E06-1-15	0SQV-063000-1000	GEARSHIFT ROD	1	
E06-1-16	0DM0-063002-00001	SHIFT POSITION SPRING PIN	1	
E06-1-17	0SQV-060013-1000	WASHER 14X28X1	1	
E06-1-18	0SQV-060002-1000	SHIFT FORK (LH & RH)	2	
E06-1-19	0SQV-060003-1000	SHIFT FORK (MIDDLE)	1	
E06-1-20	0SQV-060102-1002	FORK SHAFT	1	
E06-1-21	0SQV-060015-1001	DOWEL PIN 6	1	
E06-1-22	0700-064003	SLEEVE, SWING ARM, GEARSHIFT	1	
E06-1-23	0700-063007	SPRING, CONTACTOR	1	
E06-1-24	0700-063008	BALL CONTACTOR	1	

换档变速总成(2)/TRANSMISSION SYSTEM(2)

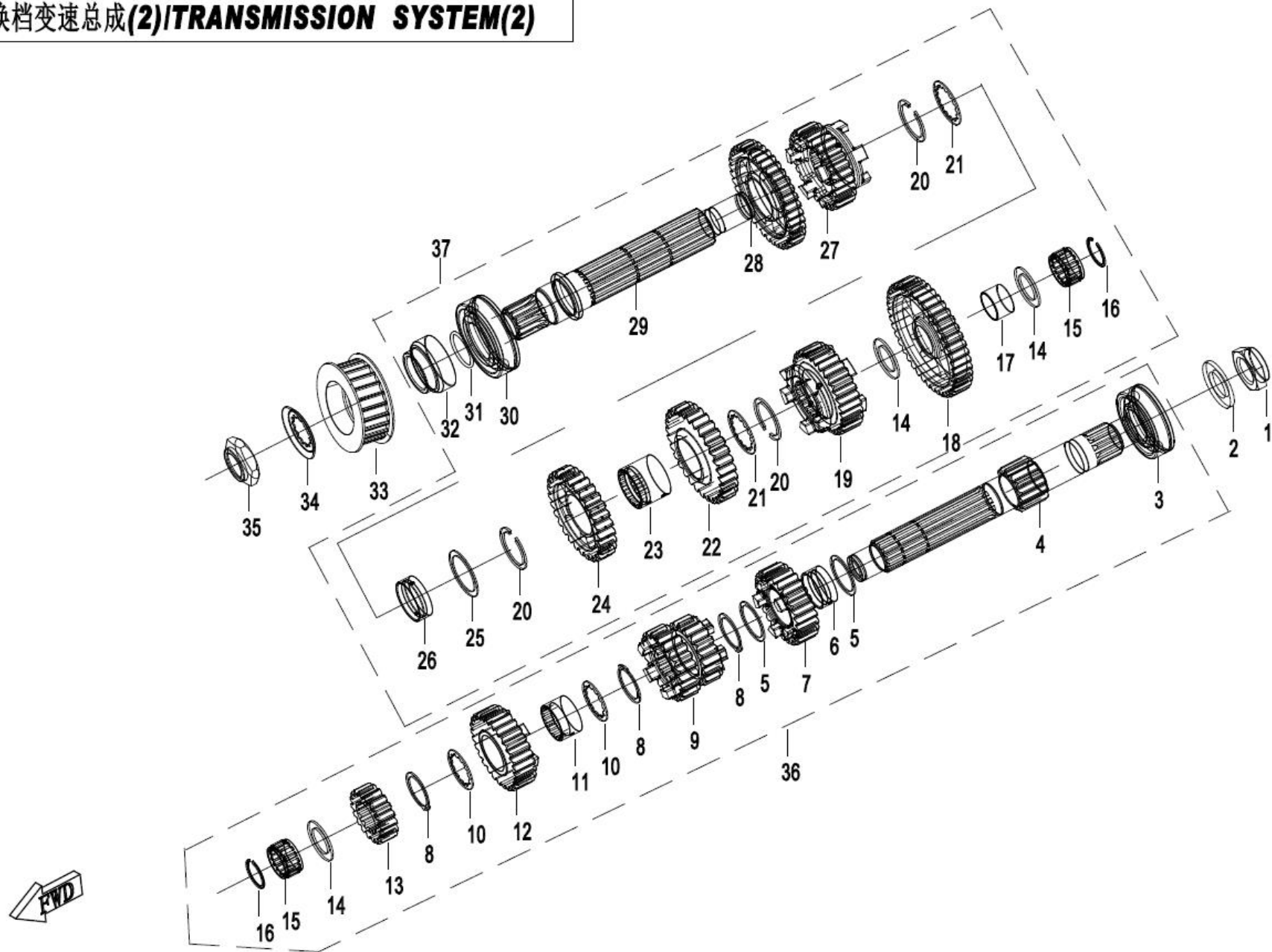

NO.	CODE	EN DESCRIPTION	QTY	REMARKS
E06-2-01	0700-061002-00002	NUT M20×1.5	1	
E06-2-02	0700-061003	CIRCLIP 20	1	
E06-2-03	0SQV-061012-1000	BEARING, MAIN SHAFT	1	
E06-2-04	0SQV-061001-1000	MAIN SHAFT	1	
E06-2-05	0SQV-061008-1000	WASHER 25.2X31X1	2	
E06-2-06	0SQV-061011-1000	BUSHING 25X28X12	1	
E06-2-07	0SQV-061009-1000	5TH GEAR, MAIN SHAFT	1	
E06-2-08	ODM0-062017	CIRCLIPS FOR SHAFT 25	3	
E06-2-09	0SQV-061007-1000	3RD4TH GEAR, MAIN SHAFT	1	
E06-2-10	ODM0-062016	SPLINE WASHER 25x31x1	2	
E06-2-11	0SQV-061006-1000	SPLINE SLEEVE	1	
E06-2-12	0SQV-061005-1000	6TH GEAR, MAIN SHAFT	1	
E06-2-13	0SQV-061003-1000	2ND GEAR, MAIN SHAFT	1	
E06-2-14	0SQV-061002-1000	WASHER 20.2X31X1.5	3	
E06-2-15	30499-02004	NEEDLE BEARING KMJ20X26X13.8X1S	2	
E06-2-16	0700-061016	CIRCLIPS FOR SHAFT20	2	
E06-2-17	0SQV-062102-1000	SHAFT SLEEVE	1	
E06-2-18	0SQV-062101-1000	1ST GEAR, COUNTERSHAFT	1	
E06-2-19	0SQV-062013-1000	5TH GEAR, COUNTERSHAFT	1	
E06-2-20	30801-02805	CIRCLIPS FOR SHAFT 28	3	
E06-2-21	0SQV-062008-1000	WASHER, SPLINE	2	
E06-2-22	0SQV-062012-1000	3RD GEAR, COUNTERSHAFT	1	
E06-2-23	0SQV-062011-1000	SPLINE SLEEVE	1	
E06-2-24	0SQV-062009-1000	4TH GEAR, COUNTERSHAFT	1	
E06-2-25	0SQV-062006-1000	28.2x36x1	1	
E06-2-26	0SQV-062005-1000	28x10.5	1	
E06-2-27	0SQV-062007-1001	6TH GEAR, COUNTERSHAFT	1	
E06-2-28	0SQV-062004-1000	2ND, COUNTERSHAFT	1	
E06-2-29	0SQV-062001-1001	COUNTERSHAFT	1	
E06-2-30	0SQV-062003-1000	62x28	1	
E06-2-31	0800-062205	O-RING 25X2	1	
E06-2-32	0SQV-062002-5000	COLLAR, COUNTERSHAFT	1	

NO.	CODE	EN DESCRIPTION	QTY	REMARKS
E06-2-33	0SQV-062030-5001	DRIVE PULLEY	1	
E06-2-34	0700-062015	WASHER	1	
E06-2-35	0SQV-060014-1001	NUT M20×1.5	1	
E06-2-36	0SQV-061000-1000	MAIN SHAFT	1	
E06-2-37	0SQV-062000-5000	COUNTERSHAFT ASSY	1	

润滑系统总成/LUBRICATION SYSTEM

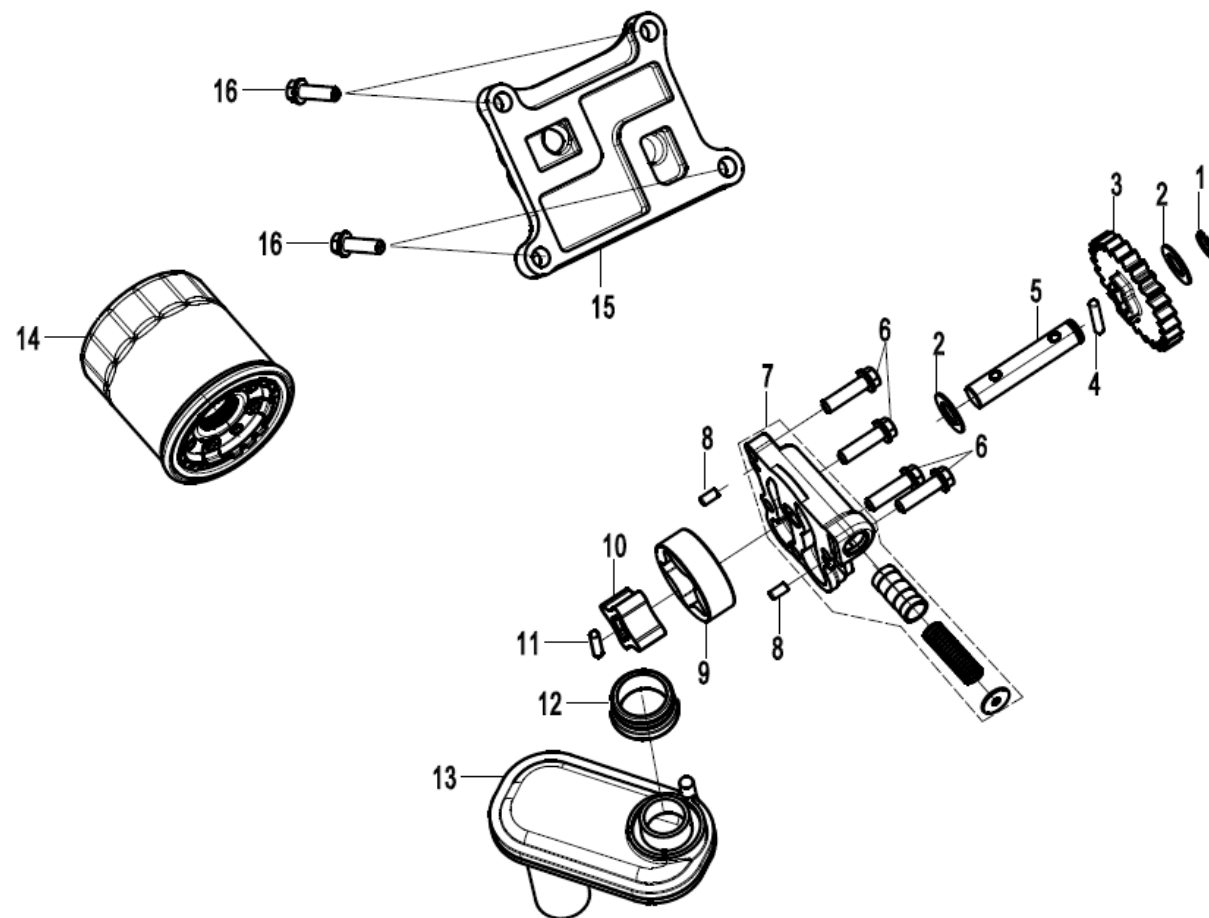

NO.	CODE	EN DESCRIPTION	QTY	REMARKS
E07-01	30801-01100	CIRCLIPS FOR SHAFT 11	1	
E07-02	0SQV-071003-1000	WASHER 11X20X1	2	
E07-03	0SQV-071001-1001	GEAR, OIL PUMP	1	
E07-04	30406-00402	ROLLER NEEDLE P4x21.8	1	
E07-05	0SQV-071002-1000	SHAFT, OIL PUMP	1	
E07-06	0010-023010-0010	BOLT M6x20	4	
E07-07	0SQV-071101-10A0	OIL PUMP COVER ASSY	1	
E07-08	30406-00401	ROLLER NEEDLE P4x7.8	2	ALT:- 920301-40078-PG2
E07-09	0700-071003	OUTER ROTOR, MAIN OIL PUMP	1	
E07-10	0700-071004	INNER ROTOR, MAIN OIL PUMP	1	
E07-11	30406-00400	ROLLER NEEDLE P4x15.8	1	
E07-12	0700-070101-00001	GASKET, OIL SUCTION PAN	1	
E07-13	0SQV-073100-1000	FILTER	1	
E07-14	0700-070200	OIL FILTER	1	
E07-15	0SQV-012010-1000-0BP00	OIL PASSAGE PLATE ASSY (MAUD SPIRIT BLACK)	1	
E07-16	0010-023008-00001	BOLT M6X18	4	ALT:- 0010-023008-0010

E08 水泵总成 WATER PUMP

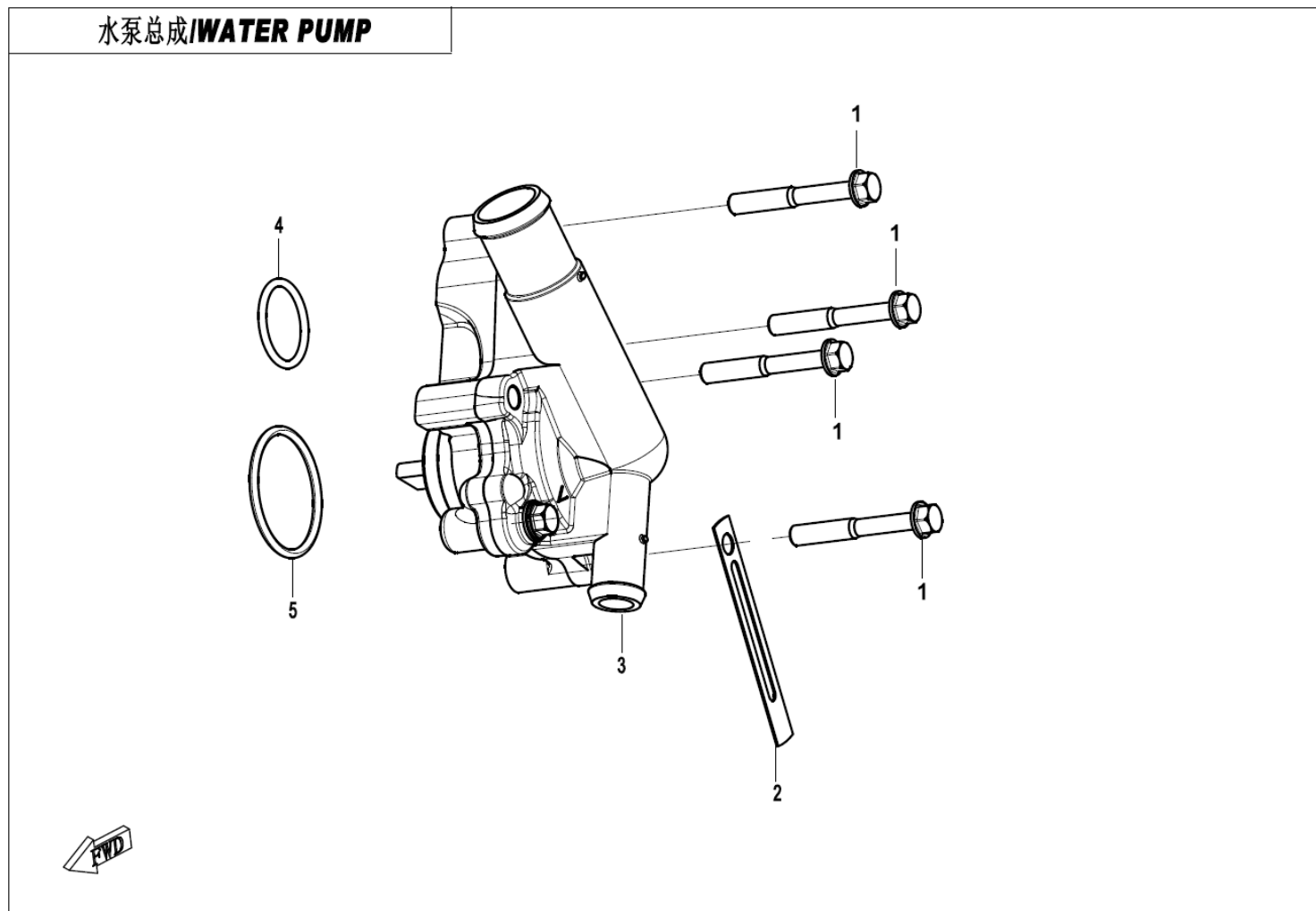

NO.	CODE	EN DESCRIPTION	QTY	REMARKS
E08-01	OHTB-065202	BOLT M6x42	4	
E08-02	0180-014010	WIRE CLIP	1	
E08-03	OSQV-081000-5000-0BP00	WATER PUMP SUB ASSY (MAUD SPIRIT BLACK)	1	
E08-04	OSQV-081009-1000	O-RING	1	
E08-05	OSQV-080002-1000	O-RING 33x2.65	1	

E09 启动系统总成 STARTING SYSTEM

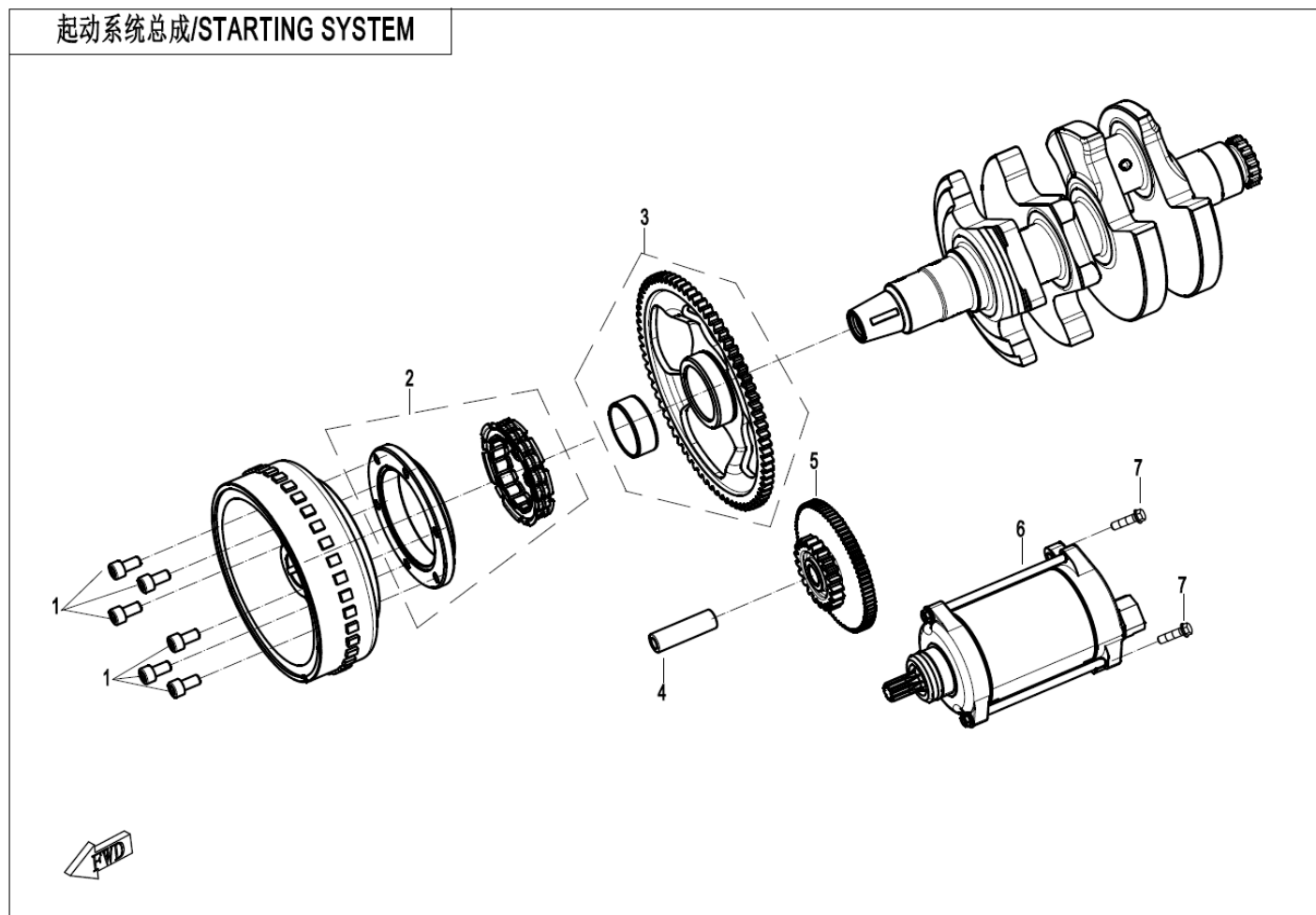

NO.	CODE	EN DESCRIPTION	QTY	REMARKS
E09-01	30102-060012810	SCREW M6X12	6	
E09-02	0SQV-091000-1001	OVERRIDING CLUTCH ASSY	1	
E09-03	0SQV-092000-1001	GEAR, STARTING MOTOR	1	ALT:- 0SQV-092000-1002
E09-04	0700-090003	SHAFT, MIDDLE GEAR	1	
E09-05	0SQV-090001-1000	DUAL GEAR	1	
E09-06	0SQV-093000-1000	STARTING MOTOR	1	
E09-07	0010-021017-0010	BOLT M6x25	2	

平衡轴总成/BALANCER SHAFT

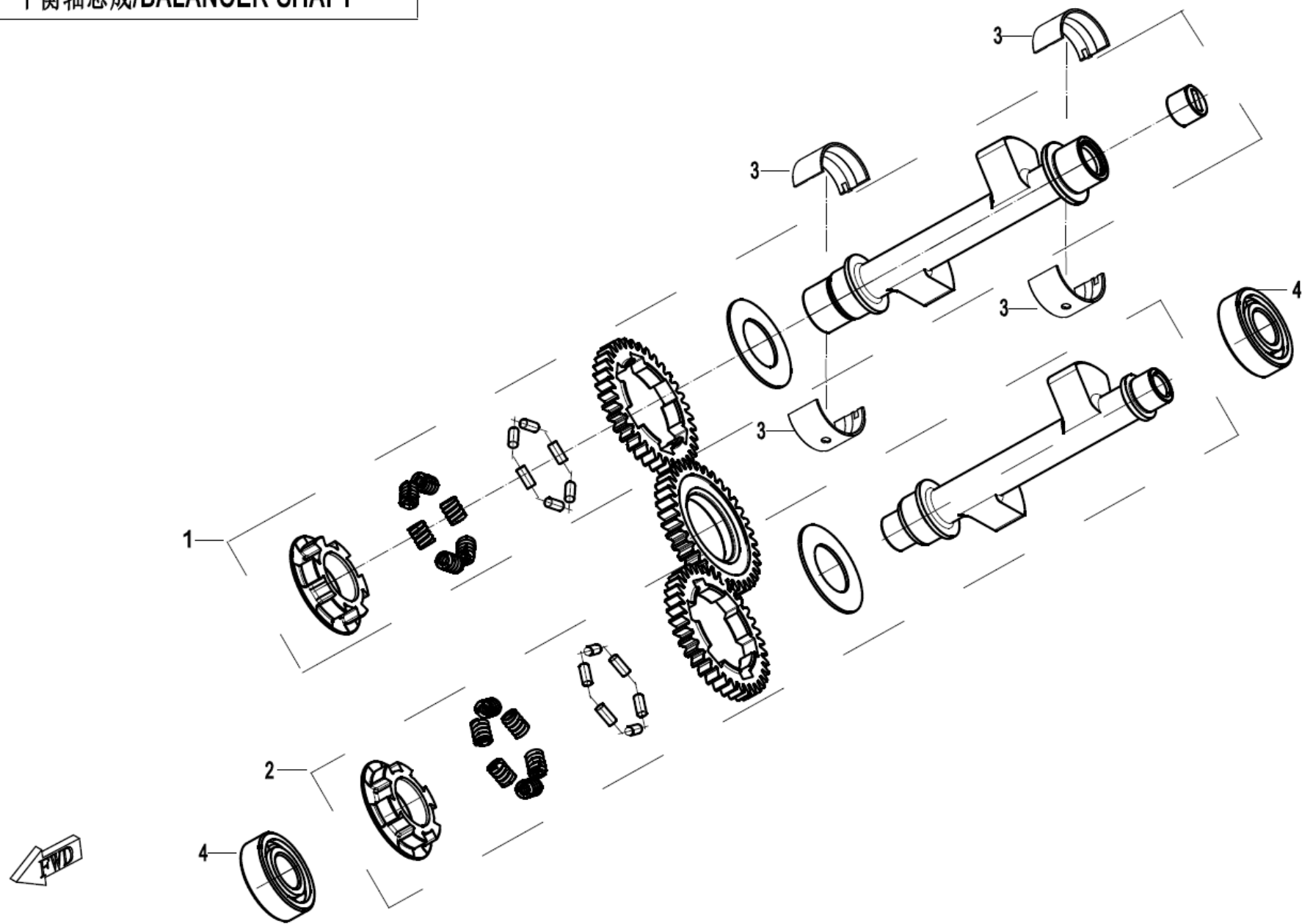

NO.	CODE	EN DESCRIPTION	QTY	REMARKS
E16-01	0SQV-161000-1000-Q0-00001	FRONT BALANCING SHAFT ASSY	1	
E16-01	0SQV-161000-1000-Q0-00002	FRONT BALANCING SHAFT ASSY	1	
E16-02	0SQV-162000-1000-Q0-00001	REAR BALANCING SHAFT ASSY	1	
E16-02	0SQV-162000-1000-Q0-00002	REAR BALANCING SHAFT ASSY	1	
E16-03	0SQV-011002-1000-Q0-00001	PLAIN BEARING, BALANCER SHAFT (RED)	4	
E16-03	0SQV-011002-1000-Q0-00002	PLAIN BEARING, BALANCE SHAFT (BLACK)	4	
E16-03	0SQV-011002-1000-Q0-00003	PLAIN BEARING, BALANCER SHAFT (BLUE)	4	
E16-04	30400-02009	BEARING	2	

节气门阀体和喷油器/THROTTLE&INJECTOR

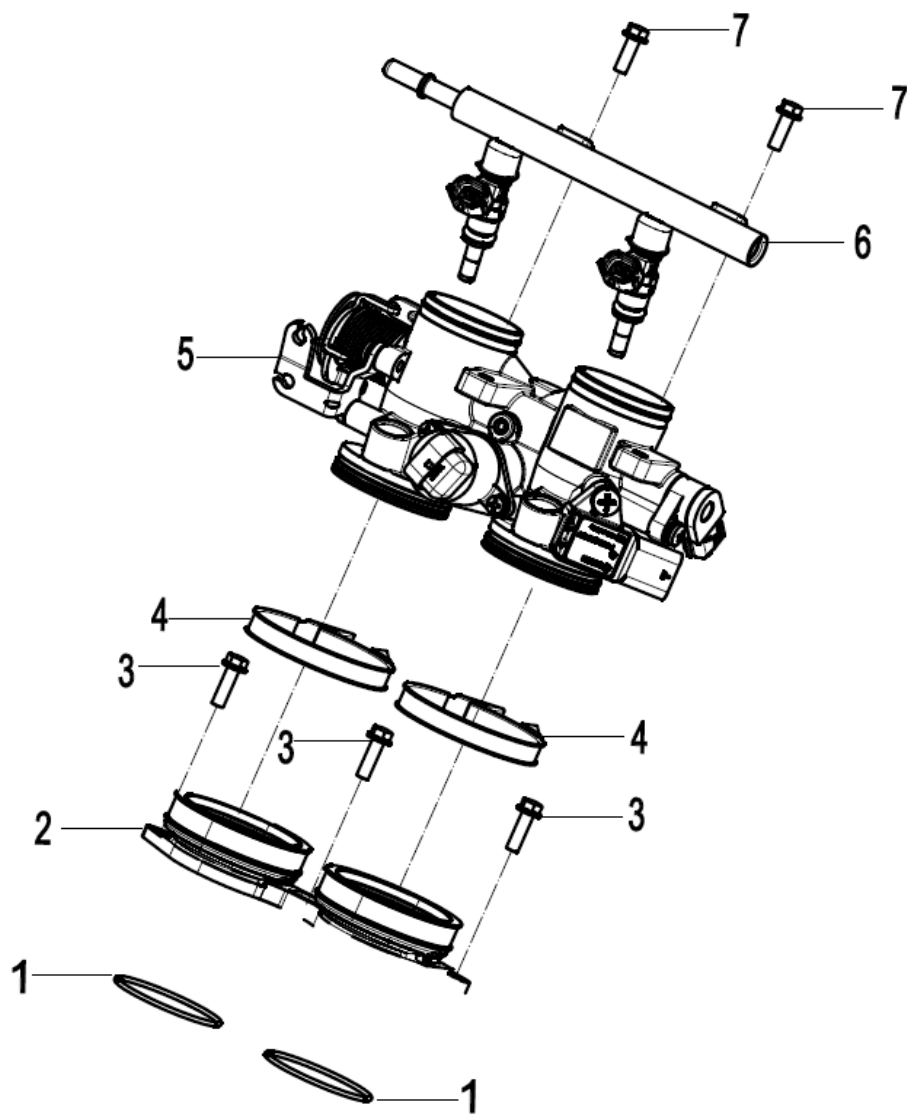

NO.	CODE	EN DESCRIPTION	QTY	REMARKS
E17-01	0SQV-022009-1000	O-RING 46.2X2	2	
E17-02	0SQV-022400-1000	CONNECTING PIPE, THROTTLE BODY	1	
E17-03	0010-023008-00001	BOLT M6X18	3	ALT:- 0010-023008-0010
E17-04	0SQV-022410-1000	CLAMP 62	2	
E17-05	0SQV-173000-5000	THROTTLE BODY ASSY	1	
E17-06	0SQV-173200-1001	FUEL PIPE ASSY	1	
E17-07	0010-090005-0010	BOLT M6x16	1	